

Contents

Act Naturally.....	3
Act Naturally G major	4
I'll always be a ukulele player	5
Always Look on the Bright Side of Life.....	6
All about that bass	7
Be My Baby.....	9
Blame it on me	10
Boogie Woogie Bugle Boy.....	11
Both Sides Now	13
Bye Bye Blackbird	14
California Dreamin'	15
Doesn't mean I love you anymore.....	17
Don't jump off the roof dad	18
Don't Dream It's Over.....	19
Georgie Girl	20
Half as Much.....	21
Hey Soul Sister.....	22
Hit The Road Jack	24
I got you babe.....	25
I'll Tell Me Ma.....	26
It's not unusual.....	28
It Doesn't Matter Anymore	29
Lazing on a sunny afternoon	30
Make your own kind of music	31
Margaritaville	32
On the Road again F major	33
On the Road again C major	34
Morningtown Ride	35
Mr Tambourine man	36
Raindrops Keep Falling On My Head	37
Space Oddity	38
Storm in a Tea-Cup	39
Streets of London	40
Sweet Sixteen	42
The Gambler.....	43
.....	43
The longest time.....	45
Three little birds	47

Top of the World	48
Travellin' Light.....	49
Upside Down	50
Walkin' My Baby Back Home	51
You to me are everything (.....	52
Constant craving.....	53
Reflections.....	54
Three Wheels on my wagon	55
Ho Hey	56
Riptide	58
Under The Boardwalk.....	60
Back in the USSR.....	61

Act Naturally (J Russell & V Morrison) Recorded by Buck Owens and the Buckaroos The Beatles in G**Count in 1 2 3 4 5****Starting note is G****Intro Play notes C B A [G7] [G7] [C]****C B A [G7] [G7] [C] [C]****[C]** They're gonna put me in the **[F]** movies.**[C]** They're gonna make a big star out of **[G7]** me.We'll **[C]**make a film about a man that's sad and **[F]** lonelyAnd **[G7]** all I gotta do is act natura-**[C]**-lly

SING G

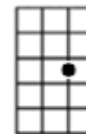
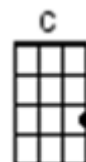
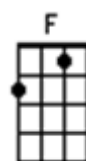
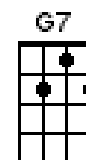
**Chorus:** Well, I'll **[G7]** bet you I'm gonna be a **[C]**big starMight **[G7]** win an Oscar you can never **[C]** tellThe **[G7]** movies gonna make me a **[C]** big star'Cause **[D]** I can play the part so **[G7]** wellWell I **[C]**hope you come and see me in the **[F]** movies**[C]** Then I'll know that you will plainly **[G7]** seeThe **[C]** biggest fool that ever hit the **[F]** big timeAnd **[G7]** all I gotta do is act natura-**[C]**-lly**Kazoo instrumental break****[C]** They're gonna put me in the **[F]** movies.**[C]** They're gonna make a big star out of **[G7]** me.We'll **[C]**make a film about a man that's sad and **[F]** lonelyAnd **[G7]** all I gotta do is act natura-**[C]**-lly**[C]** We'll make a scene about a man what's sad and **[F]** lonelyAnd **[C]** beggin down upon his bended **[G7]** kneeI'll **[C]** play the part but I won't need re-**[F]**-hearsin'And **[G7]** all I gotta do is act natura-**[C]**-lly**Repeat Chorus****Outro**Well I **[C]** hope you come and see me in the **[F]** movies**[C]** Then I'll know that you will plainly **[G7]** seeThe **[C]** biggest fool that ever hit the big **[F]** timeAnd **[G7]** all I gotta do is act natura-**[C]**-lly **[C]**And **[G7]** all I gotta do is act natura-**[C]**-lly **[F↓] [C↓]**

Act Naturally G major

(J Russell & V Morrison) Recorded by Buck Owens and the Buckaroos The Beatles in G

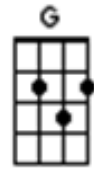
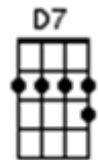
Count in 1 2 3 4 5 C F G7**Starting note is D****Intro Play notes G F# E [G7] [G7] [G]****G F# E [G7] [G7] [G] [G]****[G]** They're gonna put me in the **[C]** movies.**[G]** They're gonna make a big star out of **[D7]** me.We'll **[G]** make a film about a man that's sad and **[C]** lonelyAnd **[D7]** all I gotta do is act natura-**[G]**-lly**Chorus:** Well, I'll **[D7]** bet you I'm gonna be a **[G]** big starMight **[D7]** win an Oscar you can never **[G]** tellThe **[D7]** movies gonna make me a **[G]** big star'Cause **[D]** I can play the part so **[D7]** wellWell I **[G]** hope you come and see me in the **[C]** movies**[G]** Then I'll know that you will plainly **[D7]** seeThe **[G]** biggest fool that ever hit the **[C]** big timeAnd **[D7]** all I gotta do is act natura-**[G]**-lly**Kazoo instrumental break****[G]** They're gonna put me in the **[C]** movies.**[G]** They're gonna make a big star out of **[D7]** me.We'll **[G]** make a film about a man that's sad and **[C]** lonelyAnd **[D7]** all I gotta do is act natura-**[G]**-lly**[G]** We'll make a scene about a man what's sad and **[C]** lonelyAnd **[G]** beggin down upon his bended **[D7]** kneeI'll **[G]** play the part but I won't need re-**[C]**-hearsin'And **[D7]** all I gotta do is act natura-**[G]**-lly**Repeat Chorus****Outro**Well I **[G]** hope you come and see me in the **[C]** movies**[G]** Then I'll know that you will plainly **[D7]** seeThe **[G]** biggest fool that ever hit the big **[C]** timeAnd **[D7]** all I gotta do is act natura-**[G]**-lly **[G]**And **[D7]** all I gotta do is act natura-**[G]**-lly **[F↓] [C↓]**

I'll always be a ukulele player (Original lyrics and music by Brian Lee.)

Count in 1 2 1 2 3 4

Starting note is G

Intro [C] [C6] [C] [C6] [C] [C6] [C] [C6]

Verse 1

[C] I don't need a-[G] nother uku-[C]-lele. [C6] [C7]

[F] That's what my ex-girlfriend said to-[C]-day [C6] [C] [C6]

We [C] split because she [G] doesn't under-[C]-stand me [C6] [C] [C6]

And [G] I went out and bought one [C] anyway [C6] [C] [C6]

Verse 2

I'll [C] always be a [G] ukulele [C] player [C6] [C7]

You'll [F] hear me playing till the day I [C] die [C6] [C] [C6]

There's [C] lots of other [G] ukulele [C] players [C6] [C] [C6]

And [G] they all understand the reason [C] why [C6] [C] [C6]

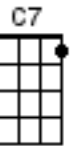
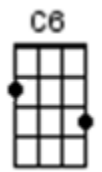
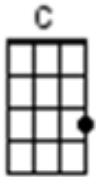
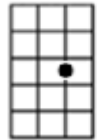

SING G

**Chorus** [C] I'm [Cdim7] a uku-[G]-lele fan

I [C] like [Cdim7] to play it [G] when I can

[C] Especially when I'm [C7] feeling low

I'll [F] pick it up and [Fm] have a go

My [C] little uku-[G]-lele makes me [C] happy [C6] [C] [C6]

Verse 3

They [C] come in all the [G] colours of the [C] rainbow [C6] [C7]

They [F] come in every size from big to [C] small [C6] [C] [C6]

But all I have's this [G] little uku-[C]-lele

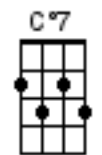
And [G] I won't rest until I've tried them [C] all [C6] [C] [C6] **Chorus****Instrumental**

[C] [Cdim7] [G] [G] : [C] [Cdim7] [G] [G] : [C] [C7] [F] [Fm] [C] [G] [C] [C]

Verse 4

If [C] everybody [G] played the uku-[C]-lele [C6] [C7]

the [F] world would be a very happy [C] place [C6] [C] [C6]

But [C] even though it [G] sometimes drives me [C] crazy [C6] [C] [C6]

I [G] always have a smile upon my [C] face [C6] [C] [C6]

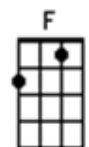
**Chorus** [C] I'm [Cdim7] a uku-[G]-lele fan

I [C] like [Cdim7] to play it [G] when I can

[C] Especially when I'm [C7] feeling low

I'll [F] pick it up and [Fm] have a go

My [C] little uku-[G]-lele makes me [C] happy [C6] [C] [C6]

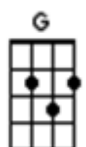
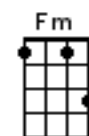

Always Look on the Bright Side of Life (Eric Idle) 1979

[Intro; Single strums ↓]

Some [Am↓] things in life are [D7-alt↓] bad

They can [G↓] really make you [Em↓] mad,

And [Am↓] other things just [D7-alt↓] make you swear and [G↓] curse

[Em↓]....When you're [Am↓] chewing on life's [D7-alt↓] gristle,

Don't [G↓] grumble.... give a [Em↓] whistle

And [A7↓] this'll help things turn out for the [D7-alt↓] best ...and...

Chorus [G] Always [Em] look on the [Am] bright [D7-alt] side of [G] life**Whistle** [Em][Am].....[D7-alt]...

[G] Always [Em] look on the [Am] light [D7-alt] side of [G] life

Whistle [Em][Am].....[D7-alt]...

If [Am] life seems jolly [D7-alt] rotten

There's [G] something you've for [Em] gotten,

And [Am] that's to laugh and [D7-alt] smile and dance and [G] sing [Em].

When you're [Am] feeling in the [D7-alt] dumps, [G] Don't be silly [Em] chumps

Just [A7] purse your lips and whistle that's the [D7-alt] thing and **Chorus**

For [Am] life is quite ab-[D7-alt]-surd and [G] death's the final [Em] word;

You must [Am] always face the [D7-alt] curtain with a [G] bow. [Em]

For-[Am]-get about your [D7-alt] sin; give the [G] audience a [Em] grin

En-[A7]-joy it; it's your last chance any-[D7-alt]-how and

Chorus [G] Always [Em] look on the [Am] bright [D7-alt] side of [G] death**Whistle** [Em]... .[Am]....[D7-alt]...

[G] Just be [Em] fore you [Am]take your [D7-alt]terminal [G] breathe.

Whistle [Em] ...[Am].....[D7-alt]...

[Am] Life's a piece of [D7-alt] sh__ [G] when you look at [Em] it.

[Am] Life's a laugh and [D7-alt] death's a joke – it's [G] true [Em]

[Am] You see it's all a [D7-alt] show; keep them [G] laughing as you [Em] go.

Just re-[A7]-member that the last laugh is on [D7-alt] you and

Outro

[G] Always [Em] look on the [Am] bright [D7-alt] side of [G] life

Whistle [Em][Am].....[D7-alt]...

[G] Always [Em] look on the [Am] light [D7-alt] side of [G] life

Whistle [Em][Am].....[D7-alt]... **Key change to A major****Coda** [A] Always [F#] look on the [Bm7] bright [E7] side of [A] life**Whistle** [F#m][Bm7].....[E7]...

[A] Always [F#m] look on the [Bm7] light [E7] side of [A] life

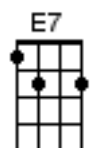
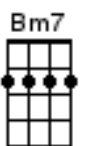
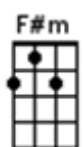
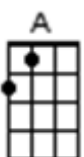
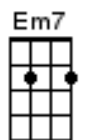
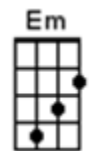
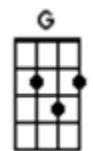
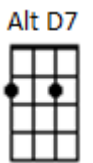
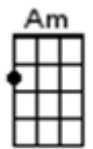
Whistle [F#m][Bm].....[E7]... [A] life **Repeat from Coda and Fade**

All about that bass Meghan Trainor

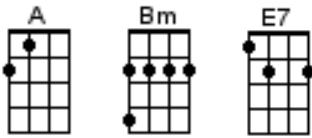

Count | 1 2 1 2 3 4

Singing note: C# {A4}

Chorus

(TACET) Because you know I'm [A] all about that bass, 'bout that bass, no treble
 I'm [Bm] all about that bass, 'bout that bass, no treble
 I'm [E7] all about that bass, 'bout that bass, no treble
 I'm [A] all about that bass, 'bout that [A↓] bass

[A] Yeah, it's pretty clear, I ain't no size two
 [Bm] But I can shake it, shake it, like I'm supposed to do
 [E7] 'Cuz I got that boom boom that all the boys chase
 And [A↓] all the right junk in all the right places

[A] I see the magazine, workin' that Photoshop
 [Bm] We know that shit - ain't - real, c'mon now, make it stop
 [E7] If you got beauty, beauty, just raise 'em up
 'Cuz every [A] inch of you is perfect
 From the [E7] bottom to the [A] top

Yeah, my [A] mama she told me don't worry about your [Bm] size [Bm]
 (Shoo wop wop, sha-oooh wop wop)
 She says, [E7] "Boys like a little more booty to hold at [A] night." [A]
 (That booty, uh, that booty booty)
 You know I [A] won't be no stick figure silicone Barbie [Bm] doll [Bm]
 (Shoo wop wop, sha-oooh wop wop)
 So if [E7] that's what you're into then go ahead and move a-[A]long [A↓]

(TACET) Because you know I'm [A] all about that bass, 'bout that bass, no treble
 I'm [Bm] all about that bass, 'bout that bass, no treble
 I'm [E7] all about that bass, 'bout that bass, no treble
 I'm [A] all about that bass, 'bout that [A↓] bass – hey!

(TACET) I'm bringing [A] booty back
 Go ahead and tell them skinny [Bm] bitches that
 No, I'm just playing, I know you [E7] think you're fat
 But I'm here to tell ya every [A] inch of you is perfect
 From the [E7] bottom to the [A] top

Yeah, my **[A]** mama she told me don't worry about your **[Bm]** size **[Bm]**
 (Shoo wop wop, sha-oooh wop wop)
 She says, **[E7]** "Boys like a little more booty to hold at **[A]** night." **[A]**
 (That booty, uh, that booty booty)
 You know I **[A]** won't be no stick figure silicone Barbie **[Bm]** doll **[Bm]**
 (Shoo wop wop, sha-oooh wop wop)
 So if **[E7]** that's what you're into then go ahead and move a-**[A]**long **[A↓]**

(TACET) Because you know I'm **[A]** all about that bass, 'bout that bass, no treble
 I'm **[Bm]** all about that bass, 'bout that bass, no treble
 I'm **[E7]** all about that bass, 'bout that bass, no treble
 I'm **[A]** all about that bass, 'bout that **[A↓]** bass

(TACET) Because you know I'm **[A]** all about that bass, 'bout that bass, no treble
 I'm **[Bm]** all about that bass, 'bout that bass, no treble
 I'm **[E7]** all about that bass, 'bout that bass, no treble
 I'm **[A]** all about that bass, 'bout that **[A]** bass

Because you know I'm **[A]** all about that bass, 'bout that bass, no treble
 I'm **[Bm]** all about that bass, 'bout that bass, no treble
 I'm **[E7]** all about that bass, 'bout that bass, no treble
 I'm **[A]** all about that bass, 'bout that bass
 'Bout that bass, 'bout that bass hey! Hey!
 Hey, **[Bm]** hey, ooh
 You know you like this **[E7]** bass, hey ey ey ey ey ey ey **[A↓]** ey

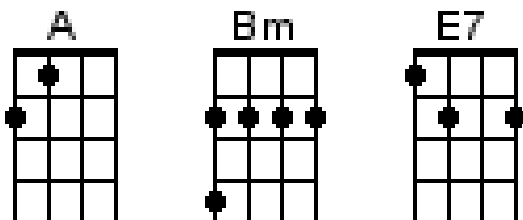

Be My Baby (Jeff Barry, Ellie Greenwich & Phil Spector) Performed by the Ronettes in E major
 Strum **D_ D UDU D_** Timing is **1_2 & 3 & 4_** Starting note is **F**

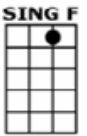

The song starts with percussion so let's tap and clap! Or Chunk

The Count in is **1 2 3 4** Tap_Tap Tap CLAP! Tap_Tap Tap CLAP! **Strum**

[F] 1 & 2 & 3 & 4 & ; **[F]** 1 & 2 & 3 & 4 & ; **[F]** 1 & 2

[F] The night we **[F]** met I knew I **[Gm]** needed you **[C7]** so
[F] And if I **[F]** had the chance I'd **[Gm]** never let you **[C7]** go
[A7] So won't you **[A7]** say you love me? **[D7]** I'll make you **[D7]** so proud of me
[G7] We'll make them **[G7]** turn their heads **[C7]** every place we **[C7]** go

So won't you **[F]** please **(Be my [F] be my baby)**
 Be my little **[Dm]** baby **(My one and [Dm] only baby)**
 Say you'll be my **[Bb]** darlin' **(Be my [Bb] be my baby)**
 Be my baby **[C7]** now..ow..ow **([C7] Oh ho ho ho)**

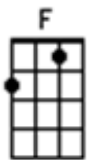

[F] I'll make you **[F]** happy baby **[Gm]** Just wait and **[C7]** see
[F] For every **[F]** kiss you give me **[Gm]** I'll give you **[C7]** three
[A7] Oh, since the **[A7]** day I saw you **[D7]** I have been **[D7]** waiting for you
[G7] You know I **[G7]** will adore you **[C7]** 'til eterni-**[C7]** -ty

So won't you **[F]** please **(Be my [F] be my baby)**
 Be my little **[Dm]** baby **(My one and [Dm] only baby)**
 Say you'll be my **[Bb]** darlin' **(Be my [Bb] be my baby)**
 Be my baby **[C7]** now..ow..ow **([C7] Oh ho ho ho)**

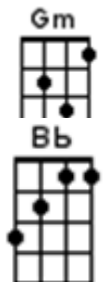
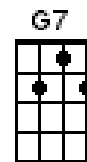

Kazoo verse over first 2 lines of verse

[F] The night we met I knew I **[Gm]** needed you **[C7]** so
[F] And if I had the chance I'd **[Gm]** never let you **[C7]** go

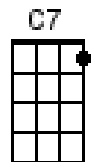
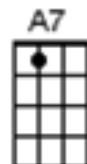

So come on and **[F]** be **(Be my [F] be my baby)**
 Be my little **[Dm]** baby **(My one and [Dm] only baby)**
 Say you'll be my **[Bb]** darlin' **(Be my [Bb] be my baby)**
 Be my baby **[C7]** now..ow..ow **([C7] Oh ho ho ho)**

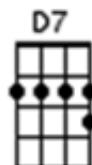
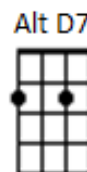

Percussion Tap_Tap Tap CLAP! Tap_Tap Tap CLAP! **Strum**
NB The **backing vocals** start first for the Outro

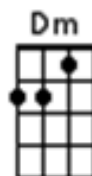

[F] **(Be my be my baby)** **[F]** Be my be little **[Dm]** baby
(My one and [Dm] only baby) Oh ho ho ho **[Bb]** ho.....o
(Be my [Bb] be my baby) Oh oh oh **[C7]** oh.....o
(My one and [C7] only baby) Oh ho ho ho **[F↓]** ho

Blame it on me (George Ezra) **Eb on record** **CHORDS**

Intro **[C]** hammer on **[Csus4]** **[Fmaj7]** The backbone of the song
[C] **[Am]** **[Csus4]** **[G]** **Maybe change to D major or F**
Ezra Strum DDUDU, DDUDU Rhythm 12&34 **D_DUDU**

Verse 1

[C] The garden was blessed by the gods of me and you
 We headed west for to find ourselves some truth
 Oh, **[Am]** what you waiting **[Csus4]** for, now what you waiting **[G]**for? **Riff**

Verse 2

[C] We counted all our reasons, excuses that we made
 We found ourselves some treasure and threw it all away
 Oh, **[Am]** what you waiting **[Csus4]** for, now what you waiting **[G]**for?
 Oh, **[Am]** what you waiting **[Csus4]** for, now what you waiting **[G]**for? **[G]**

**Pre-Chorus**

When I dance **[F]**alone and the sun's bleeding **[C]** down,
 Blame it on **[G]**me
 When I lose con**[F]**trol and the veil's over**[C]**-used,
 Blame it on **[G]**me

Chorus

[Am] Oh, what you waiting **[Csus]** for, now what you waiting **[G]**for?
[Am] Oh, what you waiting **[Csus]** for, now what you waiting **[G*]**for?
[Am] Oh, what you waiting **[Csus]** for, now what you waiting **[G]**for? **riff**

Verse 3

Caught **[C]** in the tide of blossom, caught in the carnival
 Your confidence forgotten, I see the gypsies run. Oh
[Am] What you waiting **[C]** for, now what you waiting **[G]**for? Oh
[Am] What you waiting **[C]** for, now what you waiting **[G]**for? **[G]**

Repeat pre-chorus

When I dance a **[Am]**-lone, I know, I'll **[F]** go, blame it on **[G]**me**[G]**
 When I lose con**[Am]**trol I know, I'll**[F]** go, Blame it on **[G]**me. **[G]**
[Am] Oh, what you waiting **[F]** for, now what you waiting **[G]**for? **[G]**
[Am] Oh, what you waiting **[F]** for, now what you waiting **[G]**for? **[G]**

Boogie Woogie Bugle Boy (Don Raye and Hughie Prince) (recorded by The Andrews Sisters 1941)

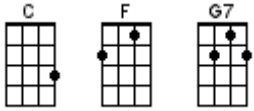

INTRO: 1 2 3 4 / [G7]/[F]/[C]/[C]

He was a [C] famous trumpet man from out Chicago way
 He [C] had a boogie style that no one else could play
 He was the [F] top man at his craft
 But then his [C] number came up and he was gone with the draft
 He's in the [G7] army now, a-blowin' [F] reveille
 He's the [C] boogie-woogie bugle boy of Company B

They [C] made him blow a bugle for his Uncle Sam
 It [C] really brought him down, because he couldn't jam
 The Captain [F] seemed to understand
 Because the [C] next day the Cap' went out and drafted a band
 And now the [G7] company jumps, when he plays [F] reveille
 He's the [C] boogie-woogie bugle boy of Company B

A-[C]↓toot, a-[C]↓toot, a-[C]toot diddle-ee-ada-toot
 He blows it [C] eight to the bar - in boogie rhythm
 He [F] can't blow a note unless the bass and guitar is playin' [C] with 'im [C]
 He makes the [G7] company jump when he plays [F] reveille
 He's the [C] boogie-woogie bugle boy of [C] Company B / [C]↓

(TACET) He was the boogie-woogie bugle boy of [C] Company B [C]
 [F] And when he played, boogie-woogie bugle
 He was [C] busy as a bzzzzz bee
 And when he [G7] plays he makes the company jump [F] eight to the bar
 He's the [C] boogie-woogie bugle boy of Company B

Toot toot toot [C] toot diddle-ee-ada, toot-diddle-ee-ada, toot toot
 He blows it [C] eight to the bar [C]
 He [F] can't blow a note if the bass and guitar isn't [C] with 'im [C]
 A-a-a-[G7]and the company jumps when he plays [F] reveille
 He's the [C] boogie-woogie bugle boy of Company B

He [C] puts the boys to sleep with boogie every night
And [C] wakes them up the same way in the early bright
They clap their [F] hands and stamp their feet
Because they [C] know how he plays when someone gives him a beat
He really [G7] breaks it up when he plays [F] reveille
He's the [C] boogie-woogie bugle boy of Company B

[C] Da-daa, da-do-da-daa

[C] Da-daa, da-do-da-daa

[F] Da-daa, da-do-da-daa

[C] Da-da, da-do-da-daa

A-a-a-[G7]and the company jumps when he plays [F] reveille

He's the [C] boogie-woogie bugle boy of Company B / [F] [G7] / [C↓][G7↓][C↓]

Both Sides Now (*Joni Mitchell*) – Judy Collins 1967 in A majorCount in 1 2, 1 & 2 & 3 & 4 & (Use **G** instead of **Bm***) Starting note D

[G] Bows and [Am] flows of [C] angel [G] hair,
 [G] And ice cream [Bm*] castles [C] in the [G] air,
 [G] And feather [C] canyons every-[Am]-where;
 [Am] I've looked at [Am] clouds that [D] way.

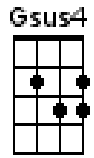
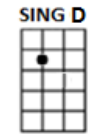
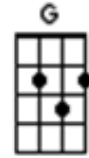

But [G] now they [Am] only [C] block the [G] sun,
 [G] They rain and [Bm*] snow on [C] every-[G]-one, [G]
 So many [C] things I [Am] would have done [Am] but clouds got in the [D] way.

[D] I've [G] looked at [Am] clouds from [C] both sides [G] now,
 From [C] up and [G] down, and [C] still some-[G]-how
 It's [Bm*] cloud's ill-[C]-usions [G] I re-[Em]-call

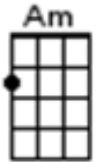

I [C] really don't know [D] clouds [D] [D] [D7-alt] at [G] all. [Gsus4] [G] [Gsus4]

[G] Moons and [Am] Junes and [C] Ferris [G] wheels,
 [G] The dizzy [Bm*] dancing [C] way you [G] feel
 [G] When every [C] fairy-tale comes [Am] real;
 [Am] I've looked at [Am] love that [D] way.

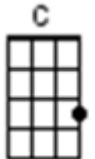
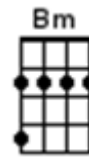

But [G] now it's [Am] just a-[C]-nother [G] show,
 [G] You leave them [Bm*] laughing [C] when you [G] go, [G]
 And if you [C] care don't [Am] let them know [Am] don't give yourself a-[D]-way.

[D] I've [G] looked at [Am] love from [C] both sides [G] now,
 From [C] give and [G] take, and [C] still some-[G]-how
 It's [Bm*] love's ill-[C]-usions [G] I re-[Em]-call

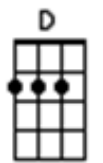

I [C] really don't know [D] love [D] [D] [D7-alt] at [G] all. [Gsus4] [G] [Gsus4]

[G] Tears and [Am] fears and [C] feeling [G] proud,
 [G] To say "I [Bm*] love you" [C] right out [G] loud;
 [G] [G] Dreams and [C] schemes and [Am] circus crowds;
 [Am] I've looked at life that [D] way.

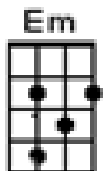

But [G] now old [Am] friends are [C] acting [G] strange,
 [G] They shake their [Bm*] heads; they [C] say I've [G] changed [G]
 But something's [C] lost [Am] and something's gained [Am] in living every [D] day

[D] I've [G] looked at [Am] life from [C] both sides [G] now,
 From [C] win and [G] lose, and [C] still some-[G]-how
 It's [Bm*] life's ill-[C]-usions [G] I re-[Em]-call

I [C] really don't know [D] life [D] [D] [D7-alt] at [G] all
 [Gsus4] [G] [Gsus4] [G] [Gsus4] [G↓]

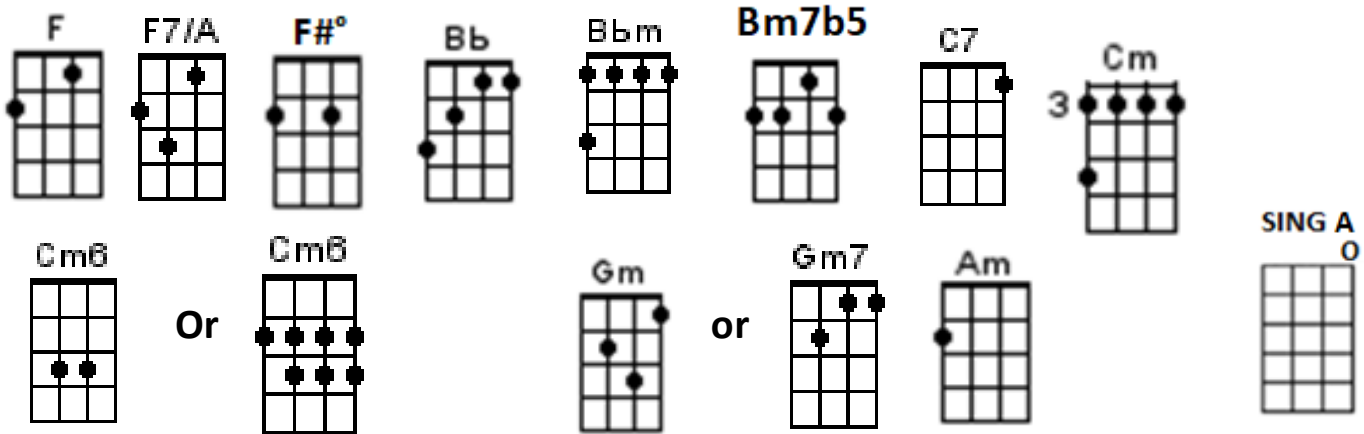
Bye Bye Blackbird (Mort Dixon, Ray Henderson)

Count in 1 2, 1 2 3 4

Starting note is A

[F] Pack up all my [Bb] care and [F] woe,
 [Am] Here I [C7] go [Gm7] singing [F] low
 [F] Bye [Bm7b5] bye [Gm7] black-[C7]-bird. [Gm7] [C7]

[Gm] Where somebody [C] waits for [Gm] me,
 [C7] Sugar's [Am] sweet so is [C7] she
 [C7] Bye [C] bye [C7] [F] blackbird.

[F7/A] No one here can love and under-[Cm]-stand [F#dim] me
 [Gm] Oh what [Gm7] hard luck [F] stories
 [G7] they all [Bbm] hand [C7] me.

[F] Make my bed and [Bb] light the [F] light,
 [Am] I'll arr-[C7]-ive [Cm6] late to-[D7]-night
 [Gm7] Blackbird [C7] bye [F] bye.

[F] Pack up all my [Bb] care and [F] woe,
 [Am] Here I [C7] go [Gm7] singing [F] low
 [F] Bye [Bm7b5] bye [Gm7] black-[C7]-bird. [Gm7] [C7]

[Gm] Where somebody [C] waits for [Gm] me,
 [C7] Sugar's [Am] sweet so is [C7] she
 [C7] Bye [C] bye [C7] [F] blackbird.

[F7/A] No one here can love and under-[Cm]-stand [F#dim] me
 [Gm] Oh what [Gm7] hard luck [F] stories
 [G7] they all [Bbm] hand [C7] me.

[F] Make my bed and [Bb] light the [F] light,
 [Am] I'll arr-[C7]-ive [Cm6] late to-[D7]-night
 [Gm7] Blackbird [C7] bye [F] bye. [C7↓] [F↓]

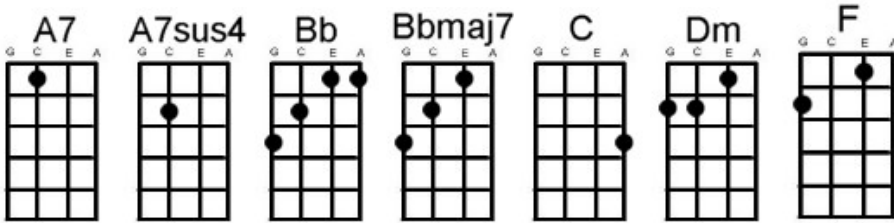

California Dreamin' (John & Michelle Phillips) The Mamas and the Papas 1965

INTRO: / 1 2 3 4 / [Dm] / [Dm] ↓

Verse 1:

All the leaves are [Dm] brown [C] / [Bb]

([Dm] *All the* [C] *leaves are* [Bb] *brown*)

And the [C] sky is [A7sus4] gray (*And the sky is* [A7] *gray*)

[Bb] I've been for a [F] walk [A7] / [Dm]

([F] *I've been* [A7] *for a* [Dm] *walk*)

On a [Bb] winter's [A7sus4] day (*On a winter's* [A7] *day*)

I'd be safe and [Dm] warm [C] / [Bb]

([Dm] *I'd be* [C] *safe and* [Bb] *warm*)

If I [C] was in L [A7sus4] A (*If I was in L* [A7] *A*)

CHORUS: California [Dm] dreamin' [C] / [Bb]

([Dm] *Cali-*[C]-*fornia* [Bb] *dreamin'*)

On [C] such a winter's [A7sus4] day [A7]

Verse 2:

Stopped in to a [Dm] church [C] / [Bb]

I passed a-[C]-long the [A7sus4] way / [A7]

Well I [Bb] got down on my [F] knees [A7] / [Dm]

([F] *Got down* [A7] *on my* [Dm] *knees*)

And I pre-[Bb]-tend to [A7sus4] pray (*I pretend to* [A7] *pray*)

You know the preacher likes the [Dm] cold [C] / [Bb]

([Dm] *Preacher* [C] *likes the* [Bb] *cold*)

He knows [C] I'm gonna [A7sus4] stay (*Knows I'm gonna* [A7] *stay*)

Chorus: California [Dm] dreamin' [C] / [Bb]

([Dm] *Cali*-[C]-*fornia* [Bb] *dreamin'*)

On [C] such a winter's [A7sus4] day [A7]

Verse 3:

All the leaves are [Dm] brown [C] / [Bb]

([Dm] *All the* [C] *leaves are* [Bb] *brown*)

And the [C] sky is [A7sus4] gray (*And the sky is* [A7] *gray*)

[Bb] I've been for a [F] walk [A7] / [Dm]

([F] *I've been* [A7] *for a* [Dm] *walk*)

On a [Bb] winter's [A7sus4] day (*On a winter's* [A7] *day*)

If I didn't [Dm] tell her [C] / [Bb]

([Dm] *If I* [C] *didn't* [Bb] *tell her*)

I could [C] leave to-[A7sus4]day (*I could leave to*-[A7]*day*)

Outro:

California [Dm] dreamin' [C] / [Bb]

([Dm] *Cali*-[C]*fornia* [Bb] *dreamin'*)

On [C] such a winter's [Dm] day (*Cali*-[C]*fornia* [Bb] *dreamin'*)

On [C] such a winter's [Dm] day (*Cali*-[C]*fornia* [Bb] *dreamin'*)

On [C] such a winter's [Bbmaj7] day / [Bbmaj7] / [Dm]↓

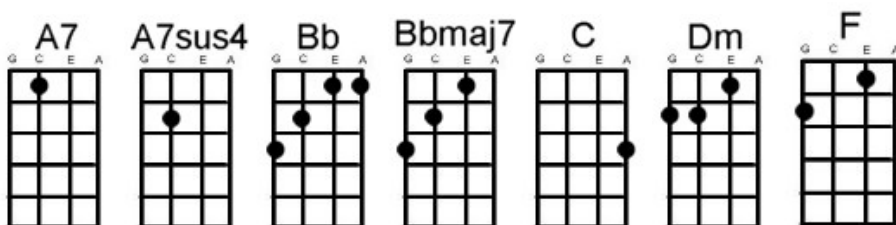

Doesn't mean I love you anymore (Michael Bublé) in F# Major BPM 90

Count in 1 2 1 2 3 4

Capo on 1st fret to play along

Check check

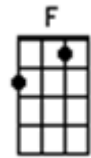
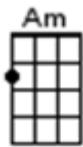
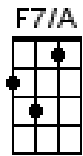
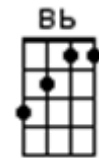
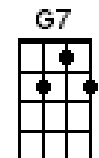
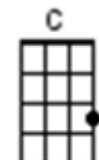
Intro [F] [Am] [F7] [Bb] [Am] [F] [G7] [C] [F] [Gm] [Dm]**[F]** Just because I wander 'round the **[Am]** places we would goHoping **[F7]** that I'd run into you one last **[Bb]** time**[Gm]** Just because I never took your **[Dm]** picture off my phone**[G7]** Doesn't mean that you're still on my **[C]** mind**[F]** Just because I accidentally **[Am]** slipped and said your nameWell, I **[F7]** heard your song, it makes me inse-**[Bb]**-cure**[Bbm]** Just because I know I'll never **[F]** ever feel the same**[G7]** Doesn't mean I **[C]** love you any-**[F]**-more**Bridge** Am I **[C]** lying to my-**[F]**-self againWhen I **[A]** say you're not the **[Bb]** best I've ever **[F]** ha.....ad?Am I **[Am]** lying to my-**[Dm]**-self againWhen I **[G7]** say that I'm not missing you so **[C]** bad?**[F]** Just because I'm on my knees and **[Am]** swearing I would changeAnd I'd do **[F7]** anything to hear you say "I'm **[Bb]** yours"**[Bbm]** Just because I know I'll never **[F]** ever feel the same**[G7]** Doesn't mean I **[C]** love you any-**[F]**-moreInstrumental Break **[F] [Am] [F7] [Bb] [Bbm] [F] [G7] [C] [F]****Bridge** Am I **[C]** lying to my-**[F]**-self againWhen I **[A]** say you're not the **[Bb]** best I've ever **[F]** ha.....ad?Am I **[Am]** lying to my-**[Dm]**-self againWhen I **[G7]** say that I'm not missing you so **[C]** bad?**[F]** Just because I'm on my knees and **[Am]** swearing I would changeAnd do **[F7]** anything to hear you say "I'm **[Bb]** yours"**[Bbm]** Just because I know I'll never **[F]** ever feel the same**[G7]** Doesn't mean I **[C]** love you any-**[F]**-more More**[G7]** Doesn't mean I **[C]** love you any-**[F]**-more Oh anymore**[G7]** Doesn't mean I **[C]** love you any-**[F]**-more

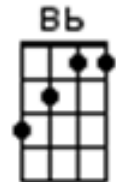
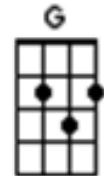
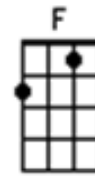
Don't jump off the roof dad*(Homer & Jethro)* Recorded by Tommy Cooper $\frac{3}{4}$ time 1961**Intro 1 2 3, 2 2 3 [F] [Dm] [C] [C7] X 4****[F]** Daddy came home from work tiredHis boss had been driving him **[C]** mad.The **[Bb]** kids were all fighting, the **[F]** dog bit him tooHis **[G]** dinner was nothing but **[C]** warmed over stew.I **[F]** guess it was then he decidedUp to the rooftop he'd **[Bb]** goHe was about to jump **[F]** off whenThe **[C7]** kids started howling be-**[F]**-low **[C7]** Oh.....**Chorus****[F]** Don't jump off the roof Dad**[Bb]** You'll make a hole in the **[F]** yard

Mother's just planted petunias

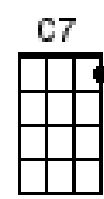
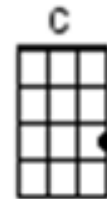
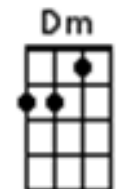
The **[G]** weeding and seeding was **[C]** hard**[F]** If you must end it all Dad**[Bb]** Won't you please give us a **[F]** break**[Bb]** Just take a walk down the **[F]** park, **[Alt D7]** DadAnd **[Bb]** there you can **[C]** jump in the **[F]** lake. **[Dm] [C] [C7]****[F] [Dm] [C] [C7]****Chorus****[F]** Don't jump off the roof Dad**[Bb]** You'll make a hole in the **[F]** yard

Mother's just planted petunias

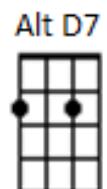
The **[G]** weeding and seeding was **[C]** hard**[F]** If you must end it all Dad**[Bb]** Won't you please give us a **[F]** break**[Bb]** Just take a walk down the **[F]** park, **[Alt D7]** DadAnd **[G7]** there you can **[C7]** jump in the **[F tremolo]** la.....ake.

Don't Dream It's Over

(Neil Finn) Performed by Crowded House

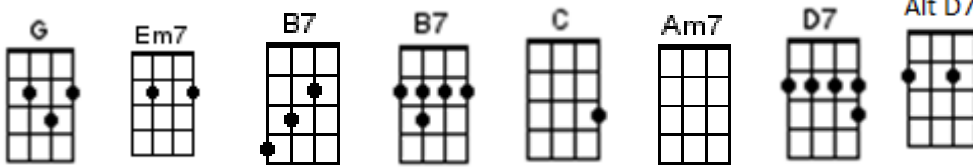
**Count in 1 & 2 & 1 &****Starting note is G, B or D****[G]** There is freedom within **[Em7]** there is freedom without **[C]**Try to catch the deluge in a paper **[B7]** cup**[G]** There's a battle ahead **[Em7]** many battles are lost **[C]**

But you'll never see the end of the road

While you're **[B7]** travelling with me**Chorus:****[Am7]** Hey now hey **[D7]** now don't **[G]** dream it's **[Em7]** over**[Am7]** Hey now hey **[D7]** now when the **[G]** world comes **[Em7]** in**[C]** They come they **[D7]** come**[G]** To build a wall be-**[Em7]**-tween us**[C]** We know that they **[C]** won't win **[D7]****[G]** Now I'm towing my car **[Em7]** there's a hole in the roof **[C]**My possessions are causing me suspicion. But **[B7]** there's no proof**[G]** In the paper today **[Em7]** tales of war and of waste **[C]**But you turn right over to the TV **[B7]** Page**[Am7]** Hey now hey **[D7]** now don't **[G]** dream it's **[Em7]** over**[Am7]** Hey now hey **[D7]** now when the **[G]** world comes **[Em7]** in**[C]** They come they **[D7]** come. **[G]** To build a wall be- **[Em7]**-ween us**[C]** We know that they **[C]** won't win **[D7]****[G]** Now I'm walking again **[Em7]** to the beat of a drum **[C]**And I'm counting the steps to the door of your **[B7]** heart**[G]** Only the shadows ahead **[Em7]** barely clearing the roof **[C]**Get to know the feeling of liberation **[B7]** and relief**[Am7]** Hey now hey **[D7]** now don't **[G]** dream it's **[Em7]** over**[Am7]** Hey now hey **[D7]** now when the **[G]** world comes **[Em7]** in**[C]** They come they **[D7]** come. **[G]** To build a wall be- **[Em7]** tween us**[C]** We know that they **[C]** won't win **[D7]** **[G↓]**

Georgie Girl (Tom Springfield and Jim Dale) The Seekers 1967

Count in 1 2, 1 2 3 4

Starting note is C

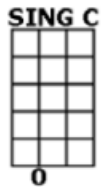

Intro: [C] [Em] [F] [G]: [C] [Em] [F] [G]

[C] Hey [Em] there, [F] Georgy [G] girl

[C] Swingin' down the [Em] street so [F] fancy-[G] free

[C] Nobody you [Em] meet could [F] ever see

The [Bb] loneliness there..... [G7↓] Inside you

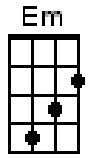
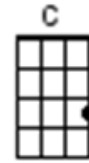

[C] Hey [Em] there, [F] Georgy [G] girl

[C] Why do all the [Em] boys just [F] pass you [G] by?

[C] Could it be you [Em] just don't [F] try

Or [Bb] is it the [G7] clothes you wear.....?

Bridge

[Am] You're always [Em] window shopping But [F] never stopping to [C] buy...

[E] Just shed those [A] dowdy [D] feathers. And [G] fly..... [G7↓] A little bit

[C] Hey [Em] there, [F] Georgy [G] girl

[C] There's another [Em] Georgy [F] deep in-[G]-side

[C] Bring out all the [Em] love you [F] hide and

[G7] Oh, what a [Am] change there'd be [Am7].....

The [F] world would see..... [G7↓] A new Georgy [C] girl

[C] [Em] [F] [G] x 2

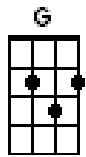
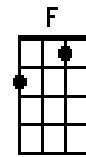

[C] Hey [Em] there, [F] Georgy [G] girl

[C] Dreamin' of the [Em] someone [F] you can [G] be

[C] Life is a re-[Em]-a- li-[F]-ty, You [Bb] can't always [G7] run away

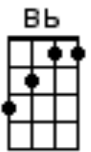
**Bridge**

[Am] Don't be so [Em] scared of changing, And [F] rearranging your [C] self....

[E] It's time for [A] jumping [D] down From the [G] shelf..... [G7↓] A little bit

[C] Hey [Em] there, [F] Georgy [G] girl

[C] There's another [Em] Georgy [F] deep in-[G]-side

[C] Bring out all the [Em] love you [F] hide and

[G7] Oh, what a [Am] change there'd be [Am7].....

The [F] world would see..... [G7↓] A new Georgy [C] girl

[C] Hey [Em] there, [F] Georgy [G] girl (Come on Georgy Girl)

[C] Hey [Em] there, [F] Georgy [G] girl (Wake up Georgy Girl)

[C] Hey [Em] there, [F] Georgy [G] girl [C↓]

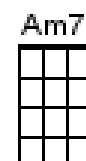
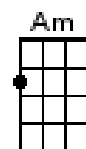

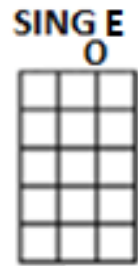
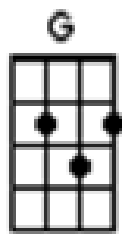
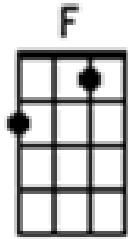
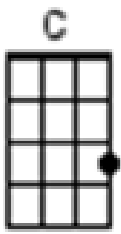
Half as Much (Curley Williams 1952) Performed by Hank Williams in D major**Count in 1 2 3 4 .1 2****Starting note is E**

If you [C] love me half as much as I love you
 You wouldn't worry me half as much as you [G] do
 You're nice to [C] me when there's no one else a-[F]-round
 You only [D] build me up to let me [G] down

If you [C] missed me half as much as I miss you
 You wouldn't stay away half as much as you [G] do
 I know that [C] I would never feel this [F] blue
 If you [G] only loved me half as much as I love [C] you

Kazoo Instrumental break

If you [C] missed me half as much as I miss you
 You wouldn't stay away half as much as you [G] do
 I know that [C] I would never feel this [F] blue
 If you [G] only loved me half as much as I love [C] you

If you [C] love me half as much as I love you
 You wouldn't worry me half as much as you [G] do
 You're nice to [C] me when there's no one else a-[F]-round
 You only [D] build me up to let me [G] down

If you [C] missed me half as much as I miss you
 You wouldn't stay away half as much as you [G] do
 I know that [C] I would never feel this [F] blue
 If you [G] only loved me half as much as I love [C] you

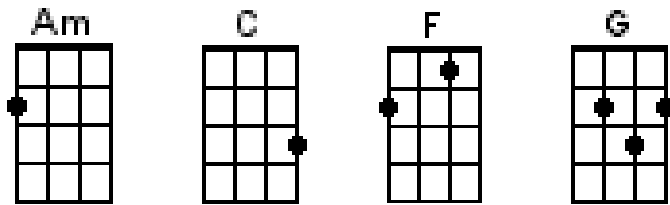

Hey Soul Sister (Patrick Monahan, Amend Bjorklund and Esen Lind) (Train) 2009**INTRO: 1 2, 1 2 3 4****[C] / [C]**

Hey-[G]ay, hey-ay-ay-[Am]ay, hey-ay-ay-[F]ay [F]



Your [C] lipstick stain [G] on the front lobe

Of my [Am] left side brain [F]

I [F] knew I wouldn't for-[C]get you

And [C] so I went and [G] let you blow my [Am] mind [Am]/[F]/[G]

Your [C] sweet moonbeam [G] the smell of you

In every [Am] single dream I [F] dream

I [F] knew when we col-[C]lided, you're the one I have de-[G]cided

Who's [G] one of my [Am] kind [Am]/[F]/[G]/

[F] Hey soul sister [G] ain't that mister [C] mister [G] on the [F] radio stereo

The [G] way you move ain't [C] fair you [G] know

[F] Hey soul sister [G] I don't want to

[C] Miss a [G] single [F] thing you do [G]/[G]↓ To-[C]night [C]

Hey-[G]ay, hey-ay-ay-[Am]ay, hey-ay-ay[F]ay [F]



[C] Just in time [G] I'm so glad

You have a [Am] one track mind like [F] me

You [F] gave my love di-[C]rection

A [C] game show love con-[G]nection, we [G] can't de-[Am]ny [Am]/[F]/[G]

I'm [C] so obsessed [G] my heart is bound to beat

Right [Am] out my untrimmed [F] chest

[F] I believe in [C] you, like a virgin you're Ma-[G]-donna

And I'm [G] always gonna [Am] wanna blow your [F] mind [G]

[F] Hey soul sister **[G]** ain't that mister **[C]** mister **[G]** on the **[F]** radio stereo
 The **[G]** way you move ain't **[C]** fair you **[G]** know
[F] Hey soul sister **[G]** I don't want to
[C] Miss a **[G]** single **[F]** thing you do **[G]/[G]**

To-**[C]**-night, the way you can cut a rug
[G] Watching you 's the only drug I **[Am]** need
 You're so gangster **[Am]** I'm so thug
 You're the **[F]** only one I'm dreaming of you **[C]** see
 I can be my-**[C]**self now final-**[G]**-ly
 In fact there's **[G]** nothing I can't **[Am]** be
 I want the **[Am]** world to see you **[F]** be with **[G]** me

[F] Hey soul sister **[G]** ain't that mister **[C]** mister **[G]** on the **[F]** radio stereo
 The **[G]** way you move ain't **[C]** fair you **[G]** know
[F] Hey soul sister **[G]** I don't want to
[C] Miss a **[G]** single **[F]** thing you do to-**[G]**night **/[C][G]/**
[F] Hey soul sister **[G]** I don't want to
[C] Miss a **[G]** single **[F]** thing you do **[G]/[G↓]**

To-**[C]**-night, hey-**[G]**ay, hey-ay-ay-**[Am]**ay, hey-ay-ay-**[F]**ay **[G]**
 To-**[C]**-night, hey-**[G]**ay, hey-ay-ay **[Am]**ay, hey-ay-ay-**[F]**ay **[G↓]**
 To-**[C↓]**-night



Hit The Road Jack *(Percy Mayfield 1960)*

Performed by Ray Charles and The Raelettes plus vocalist Margie Hendrix. in G#minor (1961)

Count in 1 2 1 2 3 4

Starting note sing E

[Am7] ↓_↓↑ [G] ↓_↓↑ [F] ↓_↓↑ [E7] ↓_↓↑ X 4

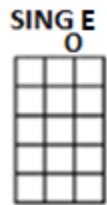

Chorus

Hit the [Am7] road [G] Jack and [F] don't you come [E7] back
No [Am7] more, no [G]more, no [F] more, no [E7] more.

Hit the [Am7]road [G]Jack and [F]don't you come [E7]back
No [Am7]more. [G] [F] *What you [E7] say?*

Hit the [Am7] road [G] Jack and [F] don't you come [E7] back
No [Am7] more, no [G]more, no [F] more, no [E7] more.

Hit the [Am7] road [G] Jack

And [F]don't you come [E7]back no [Am7]more. [G] [F] [E7]

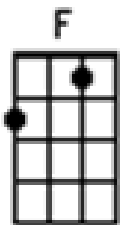
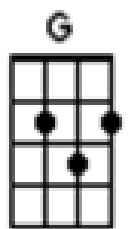
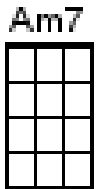

Oh [Am7] woman, oh [G]woman, don't [F]treat me so [E7] mean,
You're the [Am7]meanest old [G]woman that I've [F]ever [E7]seen.
I [Am7]guess if [G]you said [F] so.... [E7]

I'll [Am7] have to [G]pack my [F]things and [E7] go.

Chorus

Now [Am7] baby, listen [G]baby, don't-a [F] treat me this-a [E7]way
For [Am7] I'll be [G] back on my [F]feet some [E7] day.

Don't [Am7] care if you [G] do 'cause it's [F] under-[E7]-stood
You [Am7] ain't got no [G] money you're just [F] no [E7] good.

Well I [Am7] guess if [G] you said [F] so [E7]

I'd [Am7] have to pack my [G]things and [F] go. [E7]

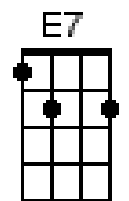

Chorus

Hit the [Am7] road [G] Jack and [F] don't you come [E7] back
No [Am7] more, no [G]more, no [F] more, no [E7] more.

Hit the [Am7]road [G]Jack and [F]don't you come [E7]back
No [Am7]more. [G] [F] *What you [E7] say?*

Hit the [Am7] road [G] Jack and [F] don't you come [E7] back
No [Am7] more, no [G]more, no [F] more, no [E7] more.

Hit the [Am7] road [G] Jack

And [F] don't you come [E7]back no [Am7] more. [G]

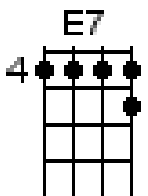

Outro

[F] Don't you come [E7] back no [Am7] more. [G]

[F] Don't you come [E7] back no [Am7] more. [G]

[F] Don't you come [E7] back no [Am7] more. [G]

[F] Don't you come [E7] back no [Am tremolo] more.....



I got you babe

(Capo 3rd fret)

(Sonny and Cher)

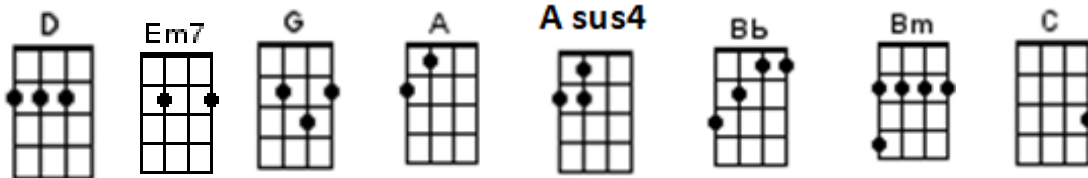
**Intro [D] [G] [D] [G]****Starting note is**

They [D] say we're young and [G] we don't know.

We [D] won't find out until [G]..i.. [C] if we [A] grow [Asus4] [A]

Well, [D] I don't know if [G] all that's true.

Cause [D] you got me, and [G] baby [C] I got [A] you [Asus4] [A]

Chorus [D] Babe [G] I got [D] you, babe [G] I got [D] you, babe

They [D] say our love won't [G] pay the rent.

Be-[D]-fore it's earned, our [G] money's [C] all been [A] spent [Asus4] [A]

I [D] guess that's so, we [G] don't have a pot.

But at [D] least I'm sure of [G] all the [C] things we [A] got [Asus4] [A]

Chorus (hold) [D] Babe [G] I got [D] you, babe [G] I got [D] you, babe [D↓]**Bridge I got [Em7] flowers in the [A] spring.**

I [Em7] got you to wear my [A] ring

And when I'm [D] sad, you're a [Bm] clown

And if I get [G] scared, you're always a-[Bb]-round.. [A] ound

So, [D] let them say your [G] hair's too long

`Cause [D] I don't care, with [G] you I [C] can't go [A] wrong [Asus4] [A]

Then [D] put your little [G] hand in mine.

There [D] ain't no hill or [G] mountain [C] we can't [A] climb [Asus4] [A]

Chorus (hold) [D] Babe [G] I got [D] you, babe [G] I got [D] you, babe**Outro**

[D] I got you to [G] hold my hand [D] I got you to [A] understand

[D] I got you to [G] walk with me [D] I got you to [A] talk with me

[D] I got you to [G] kiss goodnight [D] I got you to [A] hold me tight

[D] I got you, I [G] won't let go [D] I got you to [A] love me so

I [G] (hold) got you [D] babe [G] I got [D] you, babe

[G] I got [D] you, babe [G] I got [D] you, babe

[G] I got [D] you, babe I [G hold] got [A hold] you, [D↓] babe

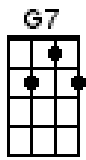
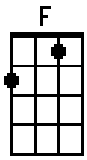
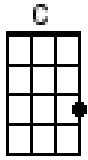

I'll Tell Me Ma (Traditional)

INTRO: / 1 2 / 1 2 / [C] / [C]

CHORUS:

I'll [C] tell me ma when [F] I get [C] home
 The [G7] boys won't leave the [C] girls alone
 They [C] pull me hair and [F] stole me [C] comb
 But [G7] that's all right, till [C] I go home
 [C↓] She is handsome [F↓] she is pretty
 [C↓] She is the Belle of [G7↓] Belfast city
 [C] She is courtin' [F↓] one [F↓] two [F↓] three
 [C] Please won't you [G7] tell me [C] who is she [C]

[C] Albert Mooney [F] says he [C] loves her
 [G7] All the boys are [C] fightin' for her
 They [C] knock on her door, they [F] ring on her [C] bell sayin'
 [G7] "Oh me true love [C] are you well?"
 [C] Out she comes as [F] white as snow
 [C] Rings on her fingers [G7] bells on her toes
 [C] Old Jenny Murphy [F] says she'll die
 If she [C] doesn't get the [G7] fella with the [C] rovin' eye

CHORUS:

I'll [C] tell me ma when [F] I get [C] home
 The [G7] boys won't leave the [C] girls alone
 They [C] pull me hair and [F] stole me [C] comb
 But [G7] that's all right, till [C] I go home
 [C↓] She is handsome [F↓] she is pretty
 [C↓] She is the Belle of [G7↓] Belfast city
 [C] She is courtin' [F↓] one [F↓] two [F↓] three
 [C] Please won't you [G7] tell me [C] who is she [C]



Let the [C] wind and the rain and the [F] hail blow [C] high
 And the [G7] snow come shovellin' [C] from the sky

[C] She's as sweet as [F] apple [C] pie
And [G7] she'll get her own lad [C] by and by
[C] When she gets a [F] lad of her own
She [C] won't tell her ma when [G7] she gets home
[C] Let them all come [F] as they will
But it's [C] Albert [G7] Mooney [C] she loves still

CHORUS:

I'll [C] tell me ma when [F] I get [C] home
The [G7] boys won't leave the [C] girls alone
They [C] pull me hair and [F] stole me [C] comb
But [G7] that's all right till [C↓] I go home

**A capella just singing and clapping**

She is handsome, she is pretty
She's the Belle of Belfast city
She is courtin' one two three
Please won't you tell me who is she

She is handsome, she is pretty
She's the Belle of Belfast city
She is courtin' one two three
Please won't you tell me who is she

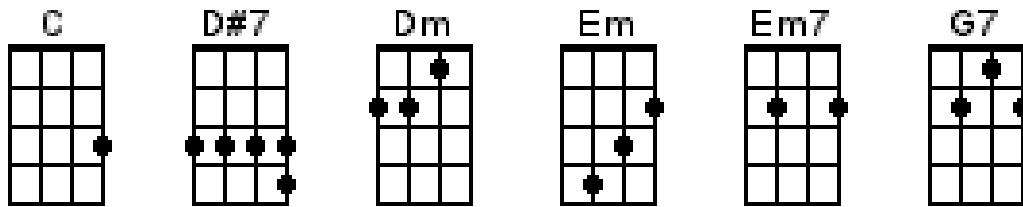
It's not unusual (*Les Reed Gordon Mills*) Performed by Tom Jones

Count in 1 2, 1, 2, 3, 4

Kazoo intro over the following chords

[C]/[C]/[Dm]/[Dm]/

[C]/[C]/[Dm]/[Dm]/

[C] It's not unusual to be [Dm] loved by anyone [G7]

[C] It's not unusual to have [Dm] fun with anyone [Dm]

[Em] But when I see you hanging a-[Dm]bout with anyone [Dm]

[G7] It's not unusual to [C] see me cry, I [Dm] wanna die [G7]

[C] It's not unusual to go [Dm] out at any time [G7]

[C] But when I see you out and a-[Dm]bout it's such a crime [Dm]

[Em] If you should ever want to be [Dm] loved by anyone [Dm]

[G7] It's not unusual, it [C] happens every day [C]

No [Dm] matter what you say [Dm]

[G7] You'll find it happens all the [C] time [C]

[C] Love will never do, [Dm] what you want it to [Dm]

[G7] Why can't this crazy love be [Em7] mine...[D#7]/[Dm]/[G7]/

[C]/[C]/[Dm]/[Dm]/:[C]/[C]/[Dm]/[Dm]/

[C] It's not unusual to be [Dm] mad with anyone [G7]

[C] It's not unusual to be [Dm] sad with anyone [Dm]

[Em] But if I ever find that you've [Dm] changed at any time [Dm]

[G7] It's not unusual, to [C] find out I'm in [Dm] love with you

Wo-oh [Em] oh oh oh oh [Dm] oh-oh, wo-oh [C] oh, oh-oh

[Dm] oh, wo-oh [Em] oh, oh, [Dm] oh-oh, wo-oh [C] oh [Dm]/[Em]/[Dm]/[C↓]

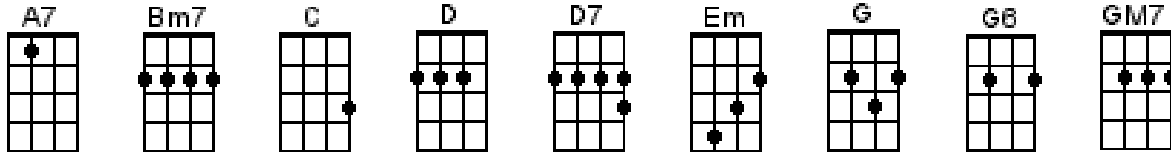

It Doesn't Matter Anymore (Paul Anka) Recorded by The Crickets 1958)

INTRO: / 1 2 3 4 /

**[G][G6] / [GMA7][G6] /
[G][G6] / [GMA7][G6] /**



[G] There you go and baby, here am I
Well you **[D7]** left me here so I could, sit and cry
Well **[G]** golly gee what have you **[Em]** done to me?
Well I **[D7]** guess it doesn't matter any-**[G]**more **[G]**

[G] Do you remember baby, last September
How you **[D7]** held me tight each and, every night?
Well **[G]** whoopsy-daisy, how you **[Em]** drove me crazy
But I **[D7]** guess it doesn't matter any-**[G]**more **[G]**

[Em] There's no use in me a-cryin'
I've **[G]** done everything and now I'm, sick of trying
I've **[A7]** thrown away my nights
And **[A7]** wasted all my days over **[D]** you **[C] / [Bm7][D7] /**

Well **[G]** you go your way and, I'll go mine
[D7] Now and forever 'til the, end of time
I'll find **[G]** somebody new, baby **[Em]** we'll say we're through
And **[D7]** you won't matter any-**[G]**more **[G]**
And **[D7]** you won't matter any-**[G]**more **[G]**
And **[D7]** you won't matter any-**[G]**more **[D7↓] [G↓]**

Lazing on a sunny afternoon (Ray Davies)[A minor] The Kinks

Count in 1 2 1 2 3 4

CHORDS

Starting note A

SING A

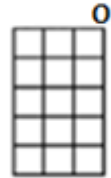
**Intro: [Dm] [Dm] [A] [A] [Dm] [Dm] [A] [A]**

The [Dm] taxman's taken [C] all my dough

And [F] left me in my [C] stately home

[A] Lazin' [A7] on a [A7+5] sunny [A7] after-[Dm]-noon

And I can't [C] sail my yacht

He's [F] taken every [C] thing I've got

[A] All I've [A7] got's this [A7+5] sunny [A7] after-[Dm]-noon [D]

[D7] Save me, save me, save me from this [G7] squeeze

I got a [C7] big fat mama tryin' to break [F] me [A7]

And I [Dm] love to live so [G7] pleasantly [Dm] Live this life of [G7] luxury

[F] Lazin' on a [A7] sunny after [Dm] noon

In the [A] summertime, In the [Dm] summertime

In the [A] summertime, In the [Dm] summertime

In the [A] summertime [A7]

My [Dm] girlfriend's run off [C] with my car

And [F] gone back to her [C] ma and pa

[A] Tellin' [A7] tales of [A7+5] drunken-[A7]-ness and [Dm] cruelty

Now I'm [C] sittin' here, [F] sippin' at my [C] ice-cold beer

[A] All I've [A7] got's this [A7+5] sunny [A7] after-[Dm]-noon [D]

[D7] Help me, help me, help me sail a-[G7]-way

Or give me [C7] two good reasons why I oughta [F] stay [A7]

Cos I [Dm] love to live so [G7] pleasantly [Dm] Live this life of [G7] luxury

[F] Lazin' on a [A7] sunny after-[Dm]-noon

[D7] Save me, save me, save me from this [G7] squeeze

I got a [C7] big fat mama [C] tryin' to [Caug] break [F] me [A7]

And I [Dm] love to live so [G7] pleasantly

[Dm] Live this life of [G7] luxury

[F] Lazin' on a [A7] sunny after-[Dm]-noon

In the [A] summertime, In the [Dm] summertime

In the [A] summertime, In the [Dm] summertime

In the [A] summertime [Dm]

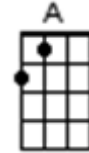
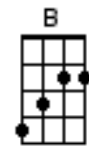
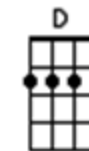
Make your own kind of music (Cynthia Weil) Mama Cass & Paloma Faith**Count in 1 2 1 2 3 4****Starting note is****Intro chords****[E]** Nobody can **[A]** tell you**[E]** There's only one song worth **[A]** singin'.**[E]** They may try and **[A]** sell ya,'cause it **[E]** hangs them up to see somone like **[B]** you.....But you've gotta **[E]** make your **[A]** own kind of music**[E]** sing your **[A]** own special song,**[E]** make your **[A]** own kind of music,**[E]** even if nobody else sings **[B]** along.....**[E]** You're gonna be **[A]** knowing**[E]** the loneliest kind of **[A]** lonely.**[E]** It may be rough **[A]** goin',just to **[E]** do your thing's, the hardest thing to **[B]** do.....But you've gotta **[E]** make your **[A]** own kind of music**[E]** sing your **[A]** own special song,**[E]** make your **[A]** own kind of music,**[E]** even if nobody else sings **[B]** along.....**Bridge****[D]** So if you cannot take my ha-**[B]**-nd,**[D]** and if you must be goin',**[B]** I will understaandYou've gotta **[E]** make your **[A]** own kind of music**[E]** sing your **[A]** own special song,**[E]** make your **[A]** own kind of music,**[E]** even if nobody else sings **[B]** along.You've gotta **[E]** make your **[A]** own kind of music**[E]** sing your **[A]** own special song,**[E]** make your **[A]** own kind of music,**[E]** even if nobody else sings **[B]** along.

Margaritaville (*Jimmy Buffet*) (Eb) (Starting note A)

1973

Count in 1&2&3&4& Rhythm 1_2&3&4 Strum D_DUDUD

[D] Nibblin' on sponge cake //// Watchin' the sun bake ////

All of those tourists covered with [A] oil ////

I'm strummin' my six-string //// On my front porch swing. ////

'Smell those shrimp, they're beginnin' to [D] boil. [D7] ////

[G] Wastin' a [A] way again in Marga-[D]-ritaville [D7] ////

[G] Searching [A] for my lost shaker of [D] salt [D7] ////

[G] Some people [A] claim that there's a [D↓] wo [A↓] man to [G↓] blame

[NC] But I [A] think //// That it's nobody's [D] fault. ////

[D] I don't know the reason. //// I stay here all season. ////

With nothin' to show but a brand new tat-[A]-too. ////

But it's a real beauty, //// a Mexican cutie. ////

How it got here, I haven't a [D] clue [D7] ////



[G] Wastin' a [A] way again in Marga-[D]-ritaville [D7] ////

[G] Searching [A] for my lost shaker of [D] salt [D7] ////

[G] Some people [A] claim that there's a [D↓] wo [A↓] man to [G↓] blame

[NC] But I [A] think. //// Hell, it could be my [D] fault. ////

[D] I blew out my flip-flop, //// stepped on a pop-top. ////

I cut my heel 'had to cruise on back [A] home. ////

But there's booze in the blender, //// And soon it will render. ////

That frozen concoction that helps me hang [D] on [D7] ////

[G] Wastin' a [A] way again in Marga [D]-ritaville [D7] ////

[G] Searching [A] for my lost shaker of [D] salt [D7] ////

[G] Some people [A] claim that there's a [D↓] wo [A↓] man to [G↓] blame.

But I [A] know it's my own damned [D] fault. ////....Yes and

Outro[G] Some people [A] claim that there's a [D] wo [A] man to [G] blame.

[NC] But I [A] know it's my own damned [D] fault//// [G↓] [D↓]

NOTE The Booze in the Blender Is a Margarita which is a mixture of Tequila, Lime juice and Cointreau with crushed ice AND Salt on the rim of the glass. Where is his shaker of salt?

On the Road again F major (Willie Nelson) Willie Nelson in E major 2/2 time 1979**Count in 1 2 3 4, 1 2****Starting note**

Chords intro Harmonica

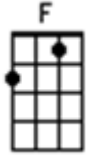
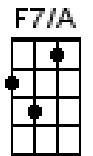
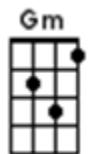
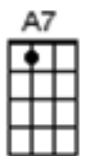
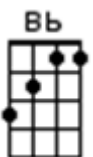
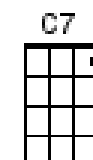
On **[F]** the Road again, just can't wait to get on the **[A7]** road againThe life I love is makin' **[Gm]** music with friendsAnd **[Bb]** I can't wait to get **[C7]** on the road a- **[F]** -gainOn the **[F]** road again, Goin' places that I've **[A7]** never beenSeeing things that I may **[Gm]** never see againAnd **[Bb]** I can't wait to get **[C7]** on the road a-**[F]**-gain **[F7/A]****Bridge** On the **[Bb]** road again,Like a band of gypsies, we go down the **[F]** highwayWe're the **[Bb]** best of friendsInsisting that the world be turning **[F]** our way...and **[C7]** our way isOn **[F]** the Road again, just can't wait to get on the **[A7]** road againThe life I love is makin' **[Gm]** music with friendsAnd **[Bb]** I can't wait to get **[C7]** on the road a- **[F]** -gainOn the **[F]** road again, Goin' places that I've **[A7]** never beenSeeing things that I may **[Gm]** never see againAnd **[Bb]** I can't wait to get **[C7]** on the road a-**[F]**-gain **[F7/A]****Bridge** On the **[Bb]** road again,Like a band of gypsies, we go down the **[F]** highwayWe're the **[Bb]** best of friendsInsisting that the world be turning **[F]** our way...and **[C7]** our way isOn the **[F]** road again, I just can't wait to get on the **[A7]** road againThe life I love is makin' **[Gm]** music with friendsAnd **[Bb]** I can't wait to get **[C7]** on the road a-**[F]**-gain **[F7/A]****[Bb]** I can't wait to get **[C7]** on the road a-**[F]**-gain **[F7/A]**

On the Road again C major (Willie Nelson) Willie Nelson in E major 2/2 time 1979**Count in 1 2 3 4, 1 2****Starting note**

Chords intro Harmonica

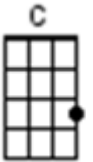
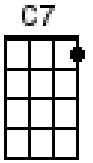
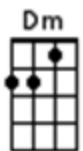
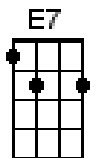
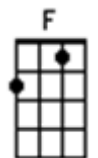
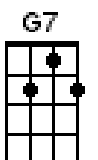
On **[C]** the Road again, just can't wait to get on the **[E7]** road againThe life I love is makin' **[Dm]** music with friendsAnd **[F]** I can't wait to get **[G7]** on the road a- **[C]** -gainOn the **[C]** road again, Goin' places that I've **[E7]** never beenSeeing things that I may **[Dm]** never see againAnd **[F]** I can't wait to get **[G7]** on the road a-**[C]**-gain **[C7]****Bridge** On the **[F]** road again,Like a band of gypsies, we go down the **[C]** highwayWe're the **[F]** best of friendsInsisting that the world be turning **[C]** our way...and **[G7]** our way isOn **[C]** the Road again, just can't wait to get on the **[E7]** road againThe life I love is makin' **[Dm]** music with friendsAnd **[F]** I can't wait to get **[G7]** on the road a- **[C]** -gainOn the **[C]** road again, Goin' places that I've **[E7]** never beenSeeing things that I may **[Dm]** never see againAnd **[F]** I can't wait to get **[G7]** on the road a-**[C]**-gain **[C7]****Bridge** On the **[F]** road again,Like a band of gypsies, we go down the **[C]** highwayWe're the **[F]** best of friendsInsisting that the world be turning **[C]** our way...and **[G7]** our way isOn the **[C]** road again, I just can't wait to get on the **[E7]** road againThe life I love is makin' **[Dm]** music with friendsAnd **[F]** I can't wait to get **[G7]** on the road a-**[C]**-gain**[C7]****[F]** I can't wait to get **[G7]** on the road a-**[C]**-gain **[C7]**

Morningtown Ride Malvina Reynolds Performed by the Seekers 1957**Count in 1 2 1 2 3 4**

[G]Train whistle [G7]blowin', [C]makes a sleepy [G]noise
 [C]Underneath their [G]blankets [Em]go [Am]all the girls and [D]boys
 [G]Rockin', rollin', [G7]ridin', [C]out along the [G]bay
 [C]All bound for [G]Morning[Em]town, [Am]many [D]miles a[G]way [D]

[G]Driver at the [G7]engine, [C]fireman rings the [G]bell
 [C]Sandman swings the [G]lantern [Em]to [Am]show that all is [D]well
 [G]Rockin', rollin', [G7]ridin', [C]out along the [G]bay
 [C]All bound for [G]Morning[Em]town, [Am]many [D]miles a[G]way [D]

[G]Maybe it is [G7]raining, [C]where our train will [G]ride
 [C]All the little [G]travellers [Em]are [Am]warm and snug [D]inside
 [G]Rockin', rollin', [G7]ridin', [C]out along the [G]bay
 [C]All bound for [G]Morning[Em]town, [Am]many [D]miles a[G]way [D]

[G]Somewhere there is [G7]sunshine, [C]somewhere there is [G]day
 [C]Somewhere there is [G]Morning[Em]town, [Am]many miles a[D]way
 [G]Rockin', rollin', [G7]ridin', [C]out along the [G]bay
 [C]All bound for [G]Morning[Em]town, [Am]many [D]miles a[G]way
 Rockin', rollin', [G7]ridin', [C]out along the [G]bay
 [C]All bound for [G]Morning[Em]town,
 (*slowly*).....[Am tremolo] many [D tremolo] miles a-[G tremolo]-way

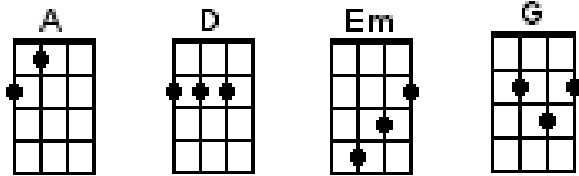

Mr Tambourine man (Bob Dylan) (1965), Recorded by The Byrds

Count in 1 2, 1 2 3 4

Lead in [D] [G]↓/[A] / [D] [G]↓/[A] /

CHORUS:

[G] Hey Mr. [A] Tambourine Man, [D] play a song for [G] me
 I'm not [D] sleepy and there [G] ain't no place I'm [A] going to [A]
 [G] Hey Mr. [A] Tambourine Man, [D] play a song for [G] me
 In the [D] jingle jangle [G] morning I'll come [A] followin' [D] you [D]

[G] Take me for a [A] trip upon your [D] magic swirlin' [G] ship
 All my [D] senses have been [G] stripped
 And my [D] hands can't feel to [G] grip
 And my [D] toes too numb to [G] step
 Wait [D] only for my [Em] boot heels to be [A] wanderin' [A]

I'm [G] ready to go [A] anywhere, I'm [D] ready for to [G] fade
 On [D] to my own pa-[G]-rade
 Cast your [D] dancing spell my [G] way
 I [Em] promise to go [A] under it [A]

**CHORUS:**

[G] Hey Mr. [A] Tambourine Man, [D] play a song for [G] me
 I'm not [D] sleepy and there [G] ain't no place I'm [A] going to [A]
 [G] Hey Mr. [A] Tambourine Man, [D] play a song for [G] me
 In the [D] jingle jangle [G] morning I'll come [A] followin' [D] you [G↓]/
 [A] / [D] [G↓]/[A] / [D] [G↓]/[A] / [D↓]

Raindrops Keep Falling On My Head (Bacharach & David) Performed by BJ Thomas

Count in 1 2 1 2 3 4

Starting note is A

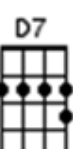
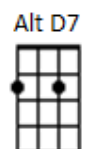
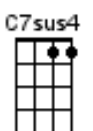
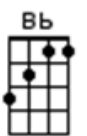
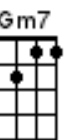
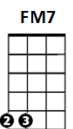
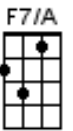
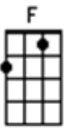
**[F] [Am7] [Gm7] [C7sus]****[F]** Raindrops keep fallin' on my **[Fmaj7]** headAnd **[F7/A]** just like the guy whose feet are **[Bb]** too big for his **[Am7]** bed.**[D7]** Nothin' seems to **[Am7]** fit**[D7]** Those **[Gm7]** raindrops are fallin' on my head they keep fallin' **[C7sus4]**So I just **[F]** did me some talkin' to the **[Fmaj7]** sunAnd **[F7/A]** I said I didn't like the **[Bb]** way he got things **[Am7]** done**[D7]** Sleepin' on the **[Am7]** job**[D7]** Those **[Gm7]** raindrops are fallin' on my head they keep fallin' **[C7sus4]****Bridge**But there's one **[F]** thi...ing I **[Fmaj7]** kno...owThe **[Bb]** blues they send to **[C]** meet me won't de-**[Am7]**-feat me..eeIt won't be long 'til **[D7]** hap-pi-ness steps **[Gm7]** up to greet me..ee**[C7sus] [C] [C7sus] [C]****[F]** Raindrops keep fallin' on my **[Fmaj7]** headBut **[F7/A]** that doesn't mean my eyes will **[Bb]** soon be turnin' **[Am7]** red**[D7]** Cryin's not for **[Am7]** me **[D7]** 'Cause**[Gm7]** I'm never gonna stop the rain by complainin' **[C7sus4]****[C7]** Because I'm **[F]** free...ee **[Am7]****[Gm7]** nothin's **[C7sus4]** worryin' **[F]** me ***Kazoo Bridge ----- *Thing I [Fmaj7] know****The [Bb] blues they send to [C] meet me won't de-[Am7]-feat me**It won't be long 'til **[D7]** hap-pi-ness steps **[Gm7]** up to greet me**[C7sus4] [C] [C7sus4] [C]****[F]** Raindrops keep fallin' on my **[Fmaj7]** headBut **[F7/A]** that doesn't mean my eyes will **[Bb]** soon be turnin' **[Am]** red**[D7]** Cryin's not for **[Am7]** me **[D7]** 'Cause**[Gm7]** I'm never gonna stop the rain by complainin' **[C7sus4]****[C7]** Because I'm **[F]** free....ee...ee **[Am7]****[Gm7]** nothin's **[C7sus4]** worryin' **[F tremolo]** me...ee...ee..ee

Space Oddity (David Bowie)

Starting note 1 2 1 2 3 4

Starting note is C

Intro: [Fmaj7] [Em] [Fmaj7] [Em]

[C] Ground control to Major [Em] Tom.

[C] Ground control to Major [Em] Tom

[Am] Take your [C] protein pills and [D7] put your helmet on

[C] Ground control to Major [Em] Tom

[C] Commencing countdown, engines [Em] on

[Am] Check ig-[C]-nition and may [D7] God's love be with you.....

[C] This is ground control to Major [E7] Tom,

You've really made the [F] grade

And the [Fm] papers want to [C] know whose shirts you [F] wear,

Now it's [Fm] time to leave the [C] capsule if you [F] dare

[C] This is Major Tom to ground con-[E7]-trol,

I'm stepping through the [F] door

And I'm [Fm] floating in the [C] most peculiar [F] way

And the [Fm] stars look very [C] different to-[F]day

For [Fmaj7] here am I [Em] sitting in a tin can,

[Fmaj7] far above the [Em] world

[Bb] Planet Earth is [Am] blue and there's [G] nothing I can [F] do

[C]-[F] [G]-[A] [A] [C]-[F] [G]-[A] [A]

[Fmaj7]/ [Em7]/ [A] [A] [C] [C] [D] [D] [E] [E]

[C] Though I'm passed one hundred thousand [E7] miles,

I'm feeling very [F] still

And I [Fm] think my spaceship [C] knows which way to [F] go,

Tell my [Fm] wife I love her [C] very much... She [F] knows.

[G] Ground control to [E7] Major Tom:

Your [Am] circuit's dead, there's [C] something wrong.

Can you [D7] hear me Major Tom? Can you [C] hear me Major Tom?

Can you [G] hear me Major Tom? Can you?

[Fmaj7] Here am I [Em] floating round my tin can,

[Fmaj7] far above the [Em] moon

[Bb] Planet Earth is [Am] blue and there's [G] nothing I can [F] do

[C]-[F] [G]-[A] [A] [C]-[F] [G]-[A] [A]

[Fmaj7]/ [Em7]/ [A] [A] [C] [C] [D] [D] [E] [E] [C↓]

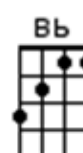
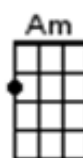
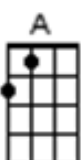
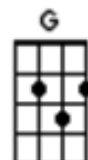
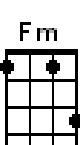
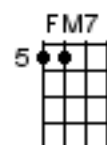
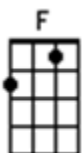
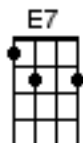
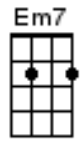
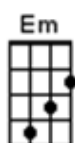
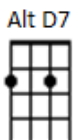
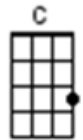
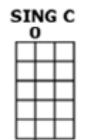

Storm in a Tea-Cup (Lynsey de Paul & Ron Baker) Performed by the Fortunes in D major

Count in 1 2 1 2 3 4

Starting note is C

[C] Pitter patter, [C] Pitter patter, [C] Pitter patter, [C] Pitter patter

[C] One drop of rain on your window pane

[C7] Doesn't mean to say there's a [F] thunderstorm comin'

[Em] Rain may pour for an [Am] hour or more

But it [Dm] doesn't matter, You know it [G] doesn't matter

[C] One gentle breeze blowin' softly through the trees

[C7] Doesn't mean to say there's a [F] hurricane hummin'

[Em] Don't start runnin' every-[Am]-time you hear it comin'

'Cause it [Dm] doesn't matter, You know it [G] doesn't matter

[C] One little word that you may have overheard

[C7] Doesn't mean to say that my [F] love for you is dyin'

[Em] Don't start cryin' over [Am] second-hand lyin'

Say it [Dm] doesn't matter, You know it [G] doesn't matter

Bridge; It's a [C] sto.....[F] orm in a teacup

[Am] Brewin' up [D] double, all those [Dm] tiny little troubles

It's a [C] stor.....[F]..orm in a teacup

It [Am] really doesn't [D] matter

If it [Dm] pitter pitter [G] patters all the [C] day

[C] One little word that you may have overheard

[C7] Doesn't mean to say that my [F] love for you is dyin'

[Em] Don't start cryin' over [Am] second-hand lyin'

Say it [Dm] doesn't matter, You know it [G] doesn't matter

Bridge; It's a [C] sto.....[F] orm in a teacup

[Am] Brewin' up [D] double, all those [Dm] tiny little troubles

It's a [C] stor.....[F]..orm in a teacup

It [Am] really doesn't [D] matter

If it [Dm] pitter pitter [G] patters all the [C] day

[C] One drop of rain on your window pane

[C7] Doesn't mean to say there's a [F] thunderstorm comin'

[Em] Rain may pour for an [Am] hour or more

But it [Dm] doesn't matter, You know it [G] doesn't matter

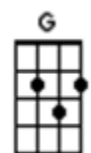
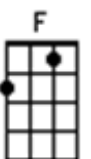
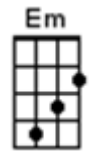
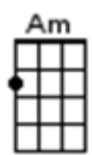
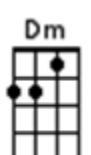
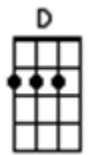
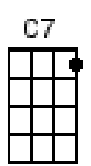
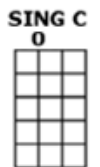
**Instrumental break and fade out????**

Streets of London

Ralph McTell (1969)

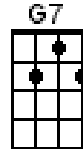
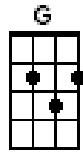
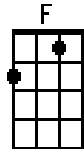
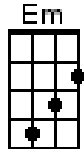
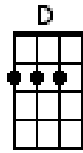
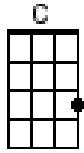
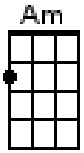
**Count in 1 2, 1 2 3 4**

[C] Have you seen the [G] old man, in the [Am] closed-down [Em] market
 [F] Kicking up the [C] paper, with his [F] worn-out [G7] shoes?
 [C] In his eyes you [G] see no pride [Am] hand held loosely [Em] at his side
 [F] Yesterday's [C] paper, telling [G7] yesterday's [C] news [C]

Chorus

So [F] how can you [Em] tell me, you're [C] lo-[Em]-one-[Am]ly
 [D] And say for you that the sun don't [G] shine [G7]
 [C] Let me take you [G] by the hand
 and [Am] lead you through the [Em] streets of London
 [F] Show you [C] something, to [G7] make you change your [C] mind

[C] Have you seen the [G] old girl, who [Am] walks the streets of [Em] London
 [F] Dirt in her [C] hair, and her [F] clothes in [G7] rags?
 [C] She's no time for [G] talking, she [Am] just keeps right on [Em] walking
 [F] Carrying her [C] home, in [G7] two carrier [C] bags [C]

Chorus

So [F] how can you [Em] tell me, you're [C] lo-[Em]-one-[Am]ly
 [D] And say for you that the sun don't [G] shine [G7]
 [C] Let me take you [G] by the hand
 and [Am] lead you through the [Em] streets of London
 [F] Show you [C] something, to [G7] make you change your [C] mind

[C] In the all-night [G] café, at a [Am] quarter past e-[Em]leven
 [F] Same old [C] man, sitting [F] there on his [G7] own
 [C] Looking at the [G] world, over the [Am] rim of his [Em] tea cup
 And [F] each tea lasts an [C] hour, and he [G7] wanders home a-[C]lone [C]

Chorus

So [F] how can you [Em] tell me, you're [C] lo-[Em]-one-[Am]ly
 [D] Don't say for you that the sun don't [G] shine [G7]
 [C] Let me take you [G] by the hand,
 and [Am] lead you through the [Em] streets of London
 [F] Show you [C] something, to [G7] make you change your [C] mind

[C] Have you seen the [G] old man, out-[Am]side the Seaman's [Em] Mission
 [F] Memory fading [C] with the medal [F] ribbons that he [G7] wears
 [C] In our winter [G] city, the rain [Am] cries a little [Em] pity
 For [F] one more forgotten [C] hero, and a [G7] world that doesn't [C] care [C]

Chorus

So [F] how can you [Em] tell me, you're [C] lo-[Em]-one-[Am]ly
 [D] And say for you that the sun don't [G] shine [G7]
 [C] Let me take you [G] by the hand,
 and [Am] lead you through the [Em] streets of London
 [F] Show you [C] something, to [G7] make you change your [C] mind [F] / [C↓]

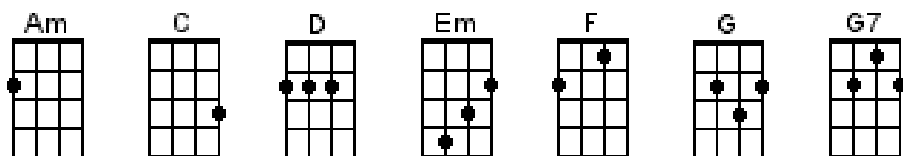

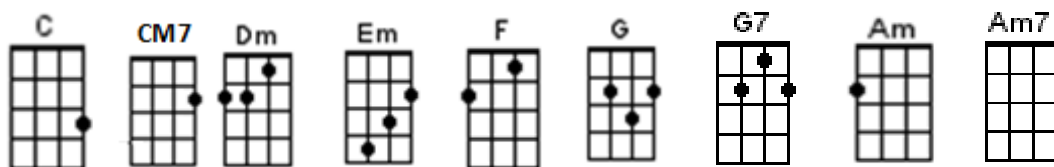
Sweet Sixteen (*James Thornton*) C Major 1898**Count in****Starting note****Instrumental banjo introduction**

When [C] first I [CMaj7] saw the [Am] love light in your [F] eyes
 I [G] thought the world held [G7] nought but joy for [C] me...[G7]
 And[C] even thou-[CMaj7]-gh we[Am] drifted [Am7]far a-[F]-part...[Dm]
 I [D] never dream but [D7] what I dream of [G] thee [G7]

Chorus

I[C] love you as I [Am] never loved be-[F]-fore...[Dm]
 Since[G] first I saw you on the village [C] green....[G7]
 Come [C] to me [CMaj7] 'ere my [Am] dreams of love is [F] o're...[Dm]
 I [D] love you as I [C] loved [CMaj7] you,
 [Am7] when you were [Em] sweet
 When you were [Dm] sweet [G7] six-[C]-teen

Repeat from the beginning

The Gambler

(Don Schlitz) Kenny Rogers and the First Edition

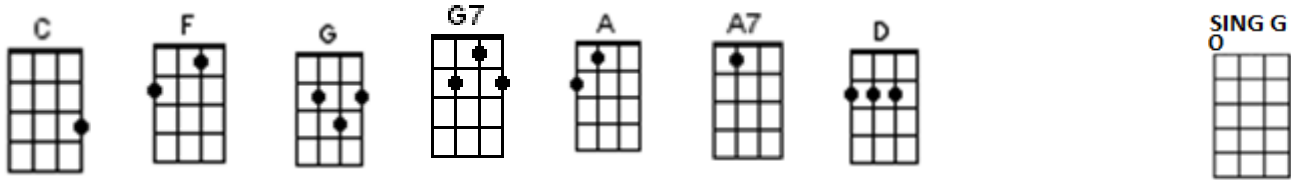

1, 2 / 1, 2 /

Starting note is G

INTRO: [C]/[F]/[C]/[F]

On a [C] warm summer's evenin', on a [F] train bound for [C] nowhere
 I [C] met up with the gambler, we were both too tired to [G7] sleep [G7]
 So [C] we took turns a-starin', out the [F] window at the [C] darkness
 Till [F] boredom over-[C]took us, [G] and he began to [C] speak

He said [C] "Son I've made a life, out of [F] readin' peoples' [C] faces
 And [C] knowin' what their cards were, by the way they held their [G7] eyes
 So if [C] you don't mind my sayin', I can [F] see you're out of [C] aces
 For a [F] taste of your [C] whiskey, I'll [G] give you some ad-[C]-vice" [C]

So I [C] handed him my bottle, and he [F] drank down my last [C] swallow
 [C] Then he bummed a cigarette, and asked me for a [G7] light
 And the [C] night got deathly quiet, and his [F] face lost all ex-[C]-pression
 'Said "if you're [F] gonna play the [C]game boy, ya gotta [G]learn to play it [C]right

Chorus

You got to [C] know when to hold 'em, [F] know when to [C] fold 'em
 [F] Know when to [C] walk away, and know when to [G] run
 You never [C] count your money, when you're [F] sittin' at the [C] table
 There'll be [C] time e-[F]-nough for [C] countin', [G] when the dealin's [C] done [C]

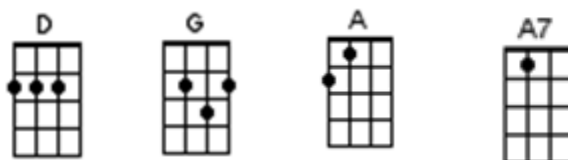

Key change [D] [D]

[D] Every gambler knows, that the [G] secret to sur-[D]-vivin'
 Is [D] knowin' what to throw away, and knowin' what to [A7] keep
 'Cause [D] every hand's a winner, and [G] every hand's a [D] loser

And the [G] best that you can [D] hope for is to [A] die in your [D] sleep.”
 And [D] when he'd finished speakin', he [G] turned back toward the [D] window
 [D] Crushed out his cigarette, and faded off to [A7] sleep
 And [D↓] somewhere in the darkness, the [G↓] gambler he broke [D↓] even
 But [G↓] in his final [D↓] words I found an [A↓] ace that I could [D] keep

Chorus

You got to [D] know when to hold 'em, [G] know when to [D] fold 'em
 [G] Know when to [D] walk away, and know when to [A] run
 You never [D] count your money, when you're [G] sittin' at the [D] table
 There'll be [D] time e-[G]-nough for [D] countin', [A] when the dealin's [D↓] done

Chorus A capella (with backing vocals)

You got to know when to hold 'em (*when to hold 'em*)
 Know when to fold 'em (*when to fold 'em*)
 Know when to walk away, and know when to run
 You never count your money, when you're sittin' at the table
 There'll be time enough for countin', when the dealin's done

You got to [D] know when to hold 'em, [G] know when to [D] fold 'em
 [G] Know when to [D] walk away, and know when to [A] run
 You never [D] count your money when you're [G] sittin' at the [D] table
 There'll be [D] time e-[G]-nough for [D] countin', [A] when the dealin's [D↓] done

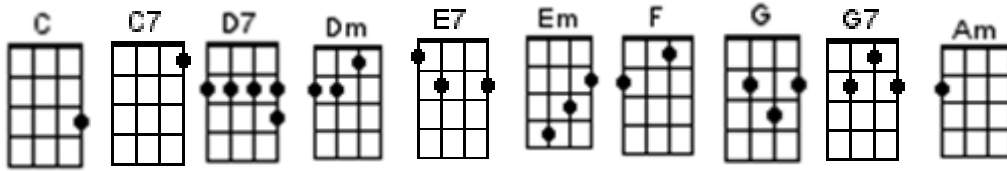
The longest time (Billy Joel)

[C] Whoa, [G] oh [C] oh [F] oh, [G7] for the longest [C] time
 [G] Whoa [C] oh [F] oh, [G7] for the longest...

[C] If you said good-[F]bye to me to-[C]night
 [C] There would still be [D7] music left to [G] write
 [E7] What else could [Am] I do? [G7] I'm so in-[C]-spired [C7] by you
 [F] That hasn't [Dm] happened for the [G] longest [C] time

[C] Once I thought my [F] innocence was [C] gone
 [C] Now I know that [D7] happiness goes [G] on
 [E7] That's where you [Am] found me,
 [G7] When you put your [C] arms a-[C7]-round me
 [F] I haven't [Dm] been there for the [G] longest [C] time

[C] Whoa, [G] oh [C] oh [F] oh, [G7] for the longest [C] time
 [G] Whoa [C] oh [F] oh, [G7] for the longest...

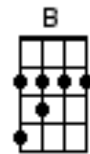

[C] I'm that voice you're [F] hearing in the [C] hall
 [C] And the greatest [D7] miracle of [G] all
 [E7] Is how I [Am] need you, [G7] And how you [C] needed [C7] me too
 [F] That hasn't [Dm] happened for the [G] longest [C] time

Bridge [G] Maybe this won't [Am] last very long
 But [B] you feel so right, and [C] I could be wrong
 [Em] Maybe I've been [Am] hoping too hard
 But [D] I've gone this [D7] far and it's [G] more than I [G7] hoped for

[C] Who knows how much [F] further we'll go [C] on?
 Maybe I'll be [D7] sorry when you're [G] gone
 [E7] I'll take my [Am] chances, [G7] I forgot how [C] nice ro-[C7]-mance is
 [F] I haven't [Dm] been there for the [G] longest [C] time

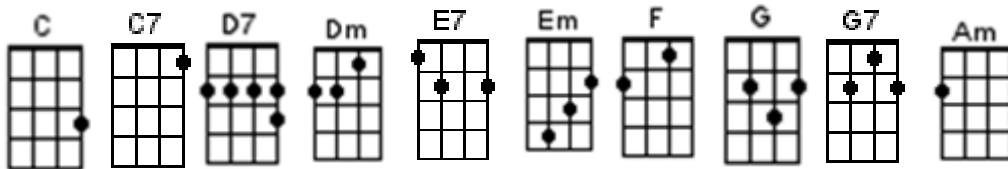

Bridge [G] I had second [Am] thoughts at the start
 I [B] said to myself hold [C] on to your heart
 [Em] Now I know the [Am] woman that you are
 You're [D] wonderful so [D7] far and it's [G] more than I [G7] hoped for

[C] I don't care what [F] consequence it [C] brings
 [C] I have been a [D7] fool for lesser [G] things
 [E7] I want [Am] you so bad, [G7] I think you [C] ought to [C7] know that
 [F] I intend to [Dm] hold you for the [G] longest [C] time

[C] Whoa, [G] oh [C] oh [F] oh, [G7] for the longest [C] time
 [G] Whoa [C] oh [F] oh, [G7] for the longest [C] time
 [G] Whoa [C] oh [F] oh, [G7] for the longest [C] time [C↓]



Three little birds (Bob Marley) Bob marley & The Wailers

Reggae strum "Up mute up" on barre chords sound good

↑ ↓ ↑

Count in 1 2 / 1 2 3 4 /

Starting note is

[A] [A] [A] [A]

Chorus Don't [A] worry, about a thing [A]

'Cause [D] every little thing, gonna be all [A] right [A]

Singin' don't [A] worry, about a thing [A]

'Cause [D] every little thing, gonna be all [A] right [A]

Rise up this [A] mornin', smiled with the [E7] risin' sun [E7]

Three little [A] birds, pitch by my [D] doorstep [D]

Singin' [A] sweet songs, of melodies [E7] pure and true [E7]

Sayin' [D] this is my message to [A] you-ou-ou [A]

Chorus Singin' don't [A] worry, about a thing [A]

Cause [D] every little thing, gonna be all [A] right [A]

Singin' don't [A] worry (*don't worry*), about a thing [A]

'Cause [D] every little thing, gonna be all [A] right [A]



Rise up this [A] mornin', smiled with the [E7] risin' sun [E7]

Three little [A] birds, pitch by my [D] doorstep [D]

Singin' [A] sweet songs, of melodies [E7] pure and true [E7]

Sayin' [D] this is my message to [A] you-ou-ou [A]

Chorus Singin' don't [A] worry, about a thing [A]

Cause [D] every little thing, gonna be all [A] right [A]

Singin' don't [A] worry (*don't worry*), about a thing [A]

'Cause [D] every little thing, gonna be all [A] right [A]

Chorus Singin' don't [A] worry, about a thing [A]

Cause [D] every little thing, gonna be all [A] right [A]

Singin' don't [A] worry (*don't worry*), about a thing [A]

'Cause [D] every little thing, gonna be all [A] right [A]

Singin' don't [A] worry, about a thing [A] (*oh no*)

'Cause [D] every little thing, gonna be all [A] right [A↓]

Top of the World Carpenters, 1973 Simplified

Count in 1 2 1 2 3 4

Starting note D

SING D

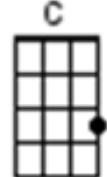
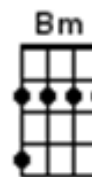
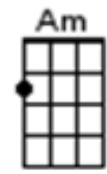
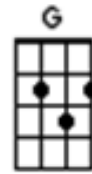
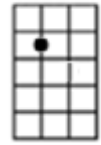
[G] Such a feelin's **[D7]** comin' over **[G]** me **[G//]**There is **[Bm]** wonder in most **[Am]** everything I **[G]** see **[G7]**Not a **[C]** cloud in the **[D7]** skyGot the **[Bm]** sun in my **[Em]** eyesAnd **[Am]** I won't be surprised if it's a **[D7]** dream**[G]** Everything I **[D7]** want the world to **[G]** be **[G//]**Is now **[Bm]** coming true es-**[Am]**-pecially for **[G]**-me **[G7]**And the **[C]** reason is **[D7]** clearIt's be-**[Bm]**-cause you are **[Em]** hereYou're the **[Am]** nearest thing to heaven that I've **[D7]** seen**Chorus** I'm on the **[G]**top of the world lookin' **[C]** down on creationAnd the **[G]** only explan-**[D7]**-ation I can **[G]** find **[G7]**Is the **[C]**love that I've **[D7]** found ever **[G]**since you've been a-**[C]**-roundYour love's **[G]**put me at the **[D7]** top of the **[G]**world**[G]** Something in the **[D7]** wind has learned my **[G]** nameAnd it's **[Bm]** tellin' me that **[Am]** things are not the **[G]** same **[G7]**In the **[C]** leaves on the **[D7]** treesAnd the **[Bm]** touch of the **[Em]** breezeThere's a **[Am]** pleasin' sense of happiness for **[D7]** me **Repeat Chorus****[G]**There is only **[D7]** one wish on my **[G]** mindWhen this **[Bm]** day is through I **[Am]** hope that I will **[G]** find **[G7]**That **[C]** tomorrow will **[D7]** beJust the **[Bm]** same for **[Em]** you and meAll I **[Am]** nee....eed will be mine if you are **[D7]** here

Alt D7

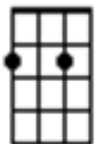

D7

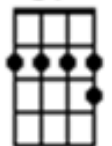

Em

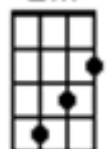
**Chorus** I'm on the **[G]** top of the world lookin' **[C]** down on creationAnd the **[G]** only explan-**[D7]**-ation I can **[G]** find **[G7]**Is the **[C]**love that I've **[D7]** found ever **[G]** since you've been a-**[C]**-roundYour love's **[G]** put me at the **[D7]** top of the **[G]**world

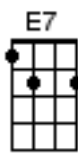
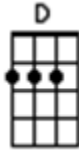
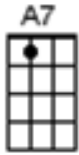
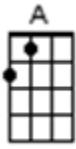
Travellin' Light (Trummy Young Jimmy Mundy & Johnny Mercer) Cliff Richard (A major) 1959

Count in 1..2..1 2 3 4

Intro [A] [A] [A] [A]

Starting note is E

[A] Got no bags 'an baggage to slow me down [A7]
 I'm [D] travelling so fast my feet ain't touching the [A] ground
 Travelling [E7] light travelling [A] light [A7]
 Well I [D] just can't wait to [E7] be with my baby to-[A]-night [A]

Bridge

[D] No comb and no tooth brush [A] I got nothing to haul [A7]
 [D] I'm carrying only a [E7↓] pocketful of dreams
 A [E7↓] heart full of love. And [E7] they weigh nothing at [E7] all
 [A] Soon, I'm gonna see that love look in her eyes [A7]
 I'm a [D] hoot and a holler away from para-[A]-dise
 Travelling [E7] light, travelling [A] light [A7]
 Well, I [D] just can't wait to [E7] be with my baby to-[A]-night [A]

Bridge

[D] No comb and no tooth brush [A] I got nothing to haul [A7]
 [D] I'm carrying only a [E7↓] pocketful of dreams
 A [E7↓] heart full of love. And [E7] they weigh nothing at [E7] all
 [A] Soon, I'm gonna see that love look in her eyes [A7]
 I'm a [D] hoot and a holler away from para-[A]-dise
 Travelling [E7] light travelling [A] light [A7]
 Well, I [D] just can't wait to [E7] be with my baby ton-[A]-ight [A]
 Well, [D] I just can't wait to [E7] be with my baby to-[A]-night [A]
 Well, I [D] just can't wait to [E7] be with my baby to-[A]-night [D↓] [A↓]



Upside Down Paloma Faith

Intro 1 2 1 2 3 4 [Dm] [Dm] [Dm] [Dm] [Gm] [Gm] [Gm] [Gm] Starting note is D
 [Dm] Angels watching over me with smiles upon their face
 'Cos [Gm] I have made it through this far in an unforgiving place
 It [Dm] feels sometimes this hill's too steep for a girl like me to climb
 But [Gm] I must knock those thoughts right down I do it in my own time
 I don't [A] care (**care care**) I'm half way [Gm] there (**nowhere**)
 On a [A] road that leads me to straight to who knows where

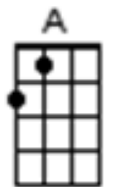
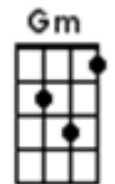
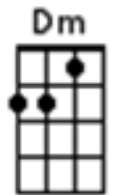
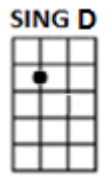

Chorus [NC] I tell you [Dm] what (**I tell you what**)
 What I have [Am] found (**what I have found**)
 That I'm no [Gm] fool (**that I'm no fool**)
 I'm just upside [Dm] down (**just upside down**)
 [Dm] Ain't got no cares (**ain't got no cares**)
 I ain't got no [Am] rules (**ain't got no rules**)
 I think I [Gm] like (**I think I like**)
 Living upside [Dm] down (**living upside down**)

[Dm] Watchin people scurry by, rushing to and fro
 Oh this [Gm] world is such a crazy place it's all about the go, go, go
 [Dm] Sometimes life can taste so sweet when you slow it down
 You [Gm] start to see the world a little differently when you turn it upside down
 I don't [A] care (**care care**) I'm half way [Gm] there (**nowhere**)
 And I'm just [A] soaking up the magic in the air

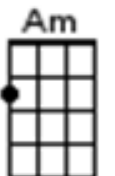

Chorus [NC] I tell you [Dm] what (**I tell you what**)
 What I have [Am] found (**what I have found**)
 That I'm no [Gm] fool (**that I'm no fool**)
 I'm just upside [Dm] down (**just upside down**)
 [Dm] Ain't got no pain (**ain't got no pain**)
 ain't got no [Am] rules (**ain't got no rules**)
 I think I [Gm] like (**I think I like**)
 Living upside [Dm] down (**living upside down**)



[Dm] (**whoa whoa whoa**) you gotta slow it down [Am] (**yeah, yeah, yeah**)
 But then you pick it up [Gm] (**whoa yeah whoa**) come on and try a little
 [Dm] Topsy-turvy, back-to-front the right way round
 [Dm] Take it slow slow slow (**you gotta pick it up**) [Am] yeah, yeah, yeah.
 (**See you slow it down**) [Gm] yo yo yo (**tell me something [Dm] something**)
Repeat Chorus X 2

Walkin' My Baby Back Home (Fred E. Ahlert/R Gauffreteau /Roy Turk)

Count in 1 2. 1 2 3 4

Starting note is G

Intro [C] [Am7] [Dm] [G7] : [C] [Am7] [Dm] [G7]

[C] Gee, it's [Am7] great after [Em7] bein' out [Am7] late
 [Em7] Walkin' my [Am7] baby back [A7] home
 [Dm] Arm in [G7] arm over [Dm] meadow and [G7] farm
 [Dm] Walkin' my [G7] baby back [C] home

[C] We go a-[Am7]-long harmon-[Em7]-izing a [Am7] song
 [Em7] Or I'm [Am7] recitin' a [A7] poem
 [Dm] Owls go [G7] by and they [Dm] give me the [G7] eye
 [Dm] Walkin' my [G7] baby back [C] home [C7]

Bridge

We [Em7] stop for a while, she [A7] gives me a smile
 And [Am7] snuggles her head on my [B7] chest
 We're [Em7] startin' to pet and [A7] that's when I get
 [Dm↓] Her talcum all [G7↓] over my vest

[C] After [Am7] I kinda [Em7] straighten my [Am7] tie
 [Em7] She has to [Am7] borrow my [A7] comb
 [Dm] One kiss [G7] then I con-[Dm]-tinue a-[G7] -gain
 [Dm] Walkin' my [G7] baby back [C] home [C7]

Bridge

She's a-[Em7]-fraid of the dark, So [A7] I have to park
 Out-[Am7]-side of her door till it's [B7] light
 She [Em7] says if I try to [A7] kiss her she'll cry
 [Dm↓] I dry her tears [G7↓] all through the night

[C] Hand in [Am7] hand to a [Em7] barbecue [Am7] stand
 [Em7] Right from her [Am7] doorway we [A7] roam
 [Dm] Eats and [G7] then it's a [Dm] pleasure a-[G7]-gain
 [Dm] Walkin' my [G7] baby, [Em7] Talkin' my [A7] baby
 [Dm] Lovin' my [G7] baby

[Em7] I don't mean [A7] maybe
 [Dm] Walkin'..... [G7↓] my baby back [C] home
 [Am7] [Dm] [G7] : [C] [Am7] [Dm] [G7] : [C6↓]

SING G

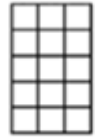

C

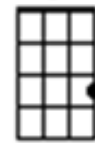

C7

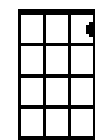

Dm

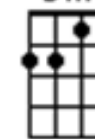

Em7

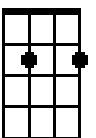

Am7

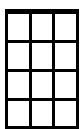

A7

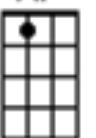

B7

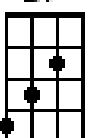

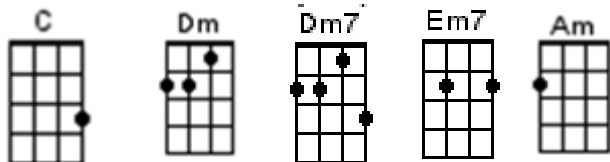
You to me are everything (Ken Gold Michael Denne) Recorded by The Real Thing**Starting note**

Count in 1 2, 1 2 3 4 Intro: [C] [Am] [Dm7] [G] X 2

[C] I would take the stars out of the sky for you,

[Am] stop the rain from falling if you asked me to.

[Dm] I'd do anything for you, your wish is my comm-**[Em7]**-and.

[Dm] I could move a mountain when your hand is in my hand. **[G]**

[C] Words cannot express how much you mean to me,

[Am] there must be some other way to make you see.

[Dm] If it takes my heart and soul, you know I'll pay **[Em7]** the price.

[Dm] Ev'rything that I possess I'd gladly sacrif-**[G]**-ice.

**Chorus**

[C] You to me are everything,

The **[G]** sweetest song that I could sing, oh **[Dm7]** baby, oh **[G]** baby!

To **[C]** you I guess I'm just a clown

Who **[G]** picks you up each time you're down, oh **[Dm7]** baby, oh **[G]** baby!

You give me **[Dm]** just a taste of love to build my hopes upon,

You know **[Dm7]** you've got the power, girl, to keep me holding on.

So now **[C]** you've got the best of me, **[G]**

Come on and **[Dm7]** take the rest of me, oh baby! **[C] [Am] [Dm7] [G]**

[C] Though you're close to me, we seem so far apart.

[Am] Maybe, given time, you'll have a change of heart.

[Dm] If it takes forever, girl, then I'm prepared to **[Em7]** wait.

[Dm] The day you give your love to me won't be a day too **[G]** late.

Chorus

[C] You to me are everything,

The **[G]** sweetest song that I could sing, oh **[Dm7]** baby, oh **[G]** baby!

To **[C]** you I guess I'm just a clown

Who **[G]** picks you up each time you're down, oh **[Dm7]** baby, oh **[G]** baby!

[D] You to me are everything, The **[A]** sweetest song that I could sing,
oh **[Em7]** baby, oh **[A]** baby

[D] You to me are everything, The **[A]** sweetest song that I could sing,
oh **[Em7]** baby, oh **[A]** baby **and fade end on a [C tremolo]**

Constant craving

Constant Craving – K.D. Lang (Capo on 1st fret) transcribed by Brian Lee

Intro (swap C5 for C if preferred)

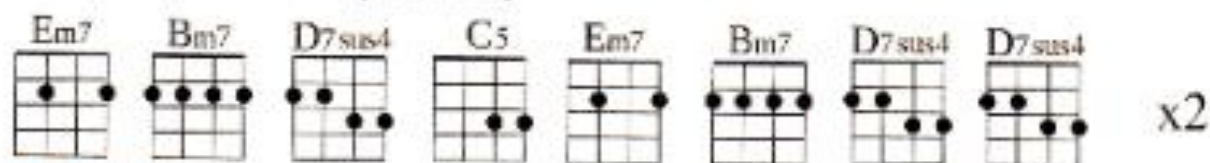

[Em7] E- [Bm7] ven through the [D7sus4] darkest [C] phase
 [Em7] Be [Bm7] it thick or [D7sus4] thin
 [Em7] Al- [Bm7] ways someone [D7sus4] marches [C] brave
 [Em7] Here be- [Bm7] neath my [D7sus4] skin

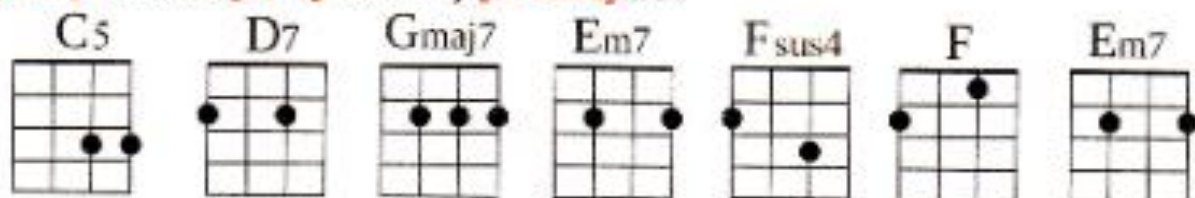

[C5] Con- [D7] stant [Gmaj7] crav- [Em7] ing has [Fsus4] al- [F] ways [Em7] been

[Em7] May- [Bm7] be a great [D7sus4] magnet [C] pulls
 [Em7] All [Bm7] souls towards [D7sus4] truth
 Or [Em7] may- [Bm7] be it is [D7sus4] life it [C] self
 feeds [Em7] wis- [Bm7] dom to its [D7sus4] youth

[C5] Con- [D7] stant [Gmaj7] crav- [Em7] ing has [Fsus4] al- [F] ways [Em7] been



[D] Crav- [C] ingah [G] ha..... constant [D add4] crav- [C] ing

Has [D] always [C] been

Has [D] always [C] been

Instrumental (same as intro)

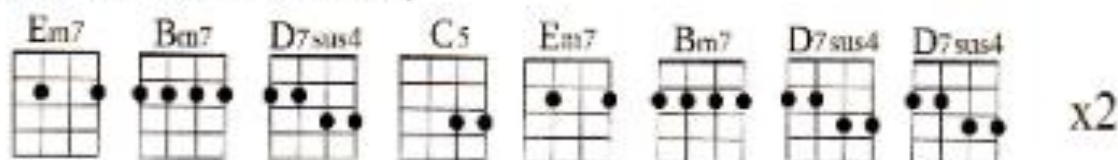

[C5] Con- [D7] stant [Gmaj7] crav- [Em7] ing has [Fsus4] al- [F] ways [Em7] been
 [C5] Con- [D7] stant [Gmaj7] crav- [Em7] ing has [Fsus4] al- [F] ways [Em7] been

[D] Crav- [C] ingah [G] ha..... constant [D add4] crav- [C] ing

Has [D] always [C] been

Has [D] always [C] been

Has [D] always [C] been

Has [D] always [C] been

(repeat to fade / finish)

Reflections (W. Junior Campbell & D Ford) Performed by The Marmalade 1969**Slow Count in 1 2 1 2 3 4****Starting note is B****[G] [Bm] [Em] [G] [C 1&2&] [C↓] [Bm↓] [Am] [D] [D]****[G]** The chang-**[Bm]** -ing of sun-**[Em]**-light to moon-**[G]**-light**[G]** Reflections **[C]** of my life **[C↓] [Bm↓] [Am]****[Am]** Oh how they fill my **[D]** ey.....eyes**[G]** The gree-**[Bm]** -tings of peop-**[Em]**-le in troub-**[G]**-le**[G]** Reflections **[C]** of my life **[C↓] [Bm↓] [Am]****[Am]** Oh how they fill my **[D]** ey.....eyes

SING B

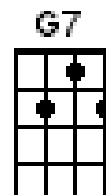
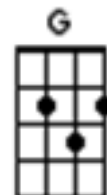
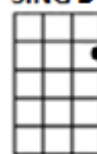
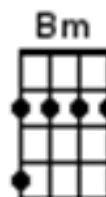
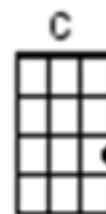
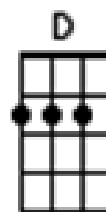
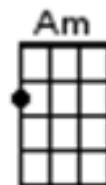
**[G]** Oh my **[Bm]** sorrows, **[Em]** sad to-**[G]**-morrrows**[C↓]** Take **[Bm↓]** me **[Am]** back to my **[D]** old home**[G]** Oh my **[Bm]** crying (Oh my **[Em]** crying)Feel I'm **[G]** dying, dying**[C↓]** Take **[Bm↓]** me **[Am]** back to my **[D]** old home**[G]** I'm changing.....**[Bm]** arranging.... **[Em]** I'm changing,**[G]** I'm changing ... **[C]** everything **[C↓] [Bm↓] [Am]****[Am]** Well everything a-**[D]**-round me.....**[G]** The world is **[Bm]** A bad place **[Em]** A bad placeA **[G]** terrible **[G7]** place **[C]** to live **[C↓] [Bm↓] [Am]****[Am]** Oh but I don't wanna **[D]** die.....**[G]** Oh my **[Bm]** sorrows, **[Em]** sad to-**[G]**-morrrows **[C]****[C↓]** Take **[Bm↓]** me **[Am]** back to my **[D]** old home**[G]** Oh my **[Bm]** crying (Oh my **[Em]** crying)Feel I'm **[G]** dying, dying**[C↓]** Take **[Bm↓]** me **[Am]** back to my **[D]** old home**[G]** Oh my **[Bm]** sorrows, **[Em]** sad to**[G]**morrrows**[C↓]** Take **[Bm↓]** me **[Am]** back to my **[D]** old home**[G]** Oh my **[Bm]** crying (Oh my **[Em]** crying)Feel I'm **[G]** dying, dying **[C]****[C]** Take **[Bm↓]** me **[Am]** back **[C]****[C↓]** Take **[C↓]** me **[G tremolo]** back

Three Wheels on my wagon (Hilliard and music by Burt Bacharach) 1961

The New Christy Minstrels (C#)

Intro: Discordant pluck on [C +Eb] **Count** 1&2&3&4& **Rhythm** ↓↑ ↓↑

[G]Three wheels [B7]on my [Em]wagon, and [Am]I'm still [G]rolling a[D7] long,

The [G] Chero[Em] kees are [C]chasing [D7]me,

[C] Arrows [D7]fly [C]right on [D7] by

But I'm [G] singing a [C]happy [G↓]so.[C↓].o.[G↓]ong. I'm singing

[C]Higgety, haggety, [G] hoggety, high, [D7] Pioneers, they [G] never say die,

A [C] mile up the road there's a [G] hidden cave,

And we can [Am]watch those Cherokees[D7↓] Go galloping[G] by. [C] [G]

[G]Two wheels [B7]on my [Em]wagon, and [Am]I'm still [G]rolling a[D7] long,

Them [G] Chero[em] kees are [C]after [D7]me,

[C]Flaming [D7]spears [C]burn my [D7]ears,

But I'm [G] singing a [C]happy [G↓]so.[C↓].o.[G↓].ong

[C]Higgety, haggety, [G] hoggety, high, [D7] Pioneers, they [G] never say die,

Half a [C] mile up the road there's a [G] hidden cave,

And we can [Am]watch those Cherokees[D7↓] Go galloping[G] by. [C] [G]

[G]One wheel [B7]on my [Em]wagon, And [Am]I'm still [G]rolling a[D7] long,

Them [G] Chero[Em]kees are [C]after [D7]me,

[C]All in [D7] flames [C] at the [D7]reins

But I'm [G] singing a [C]happy [G↓]so.[C↓].o.[G↓]ong

[C]Higgety, haggety, [G] hoggety, high, [D7] Pioneers, they [G] never say die,

Right a [C]round that turn there's a[G] hidden cave,

And we can [Am]watch those Cherokees[D7↓] Go galloping[G] by. [C] [G]

[G]No wheels [B7]on my [Em]wagon, so [Am]I'm not [G]rolling a[D7] long,

The [G] Chero[Em]kees have [C]captured [D7]me,

[C]They look [D7]mad. [C]Things look [D7]bad

But I'm [G] singing a [C]happy [G↓]so.[C↓].o.[G↓]ong

Spoken: "C'mon all you Cherokees sing along with me!"

I'm singing..... (Whooping noises)

[C]Higgety, haggety, [G] hoggety, high, [D7] Pioneers, they [G] never say die

'A singing [C]Higgety, haggety, [G] hoggety, high, [D7] Pioneers, they never say

[G↑] die.....

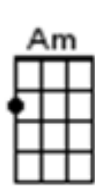
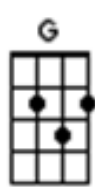
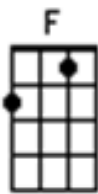
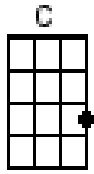

Ho Hey The Lumineers

Include C sus chord here too

There are three distinct strum patterns in this song

The first pattern is mainly on the C chord in the verse ↓↓↑↑↓

The second one for the chorus is ↓_↑↑↓ ↑↓↑

The third one involves a root note followed by a strum ie root strum

[H]

INTRO: [Csus4] ↑↓ [C] ↓↓↑↑↓ Ho [Csus4] ↓ [C] ↓_↓↑_↑↓ Hey
[Csus4] ↓↓ [C] Ho [Csus4] ↓ [C] Hey [F] ↓

[C] ↓↓↑↑↓↓↑ as the song progresses

[C] (Ho) I've been trying to do it right [F] ↓↓

[C] (Hey) I've been living a lonely life [F] ↓↓

[C] (Ho) I've been sleeping here instead [F] ↓↓

[C] (Hey) I've been sleeping in my bed [F] ↓↓

[Am] (Ho) Sleepin' [G] in my bed

[F] ↓ [C] Hey [F] ↓↓ [C] Ho [F] ↓↓

[C] (Ho) So show me family [F] ↓↓

[C] (Hey) All the blood that I will bleed [F] ↓↓

[C] (Ho) I don't know where I belong [F] ↓↓

[C] (Hey) I don't know where I went wrong [F] ↓↓

[Am] (Ho) But I can [G] write a song [F] ↓ [C] Hey- two, three

CHORUS: root chord x2 root chord ↓↓

I belong with [Am] you, you belong with [G] me [F]??

You're my sweet [C] heart [C]

I belong with [Am] you, you belong with [G] me



You're my sweet [C] Ho [F]↓↓[C] Hey [F]↓↓[C] Ho [F]↓↓[C] Hey [F]↓↓
 [C] (Ho) I don't think you're right for him [F]↓↓
 [C] (Hey) Think of what it might've been [F]↓↓ if you
 [C] (Ho) Took a bus to Chinatown [F]↓↓
 [C] (Hey) I'd be standing on Canal [F]↓↓
 [Am] (Ho)...and [G] Bowery [F]↓ [C] (Hey)
 [Am] (Ho) She'd be standing [G] next to me [F]↓ [C] Hey- two, three

CHORUS:

I belong with [Am] you, you belong with [G] me
 You're my sweet-[C]heart [C]
 I belong with [Am] you, you belong with [G] me
 You're my sweet-[C]heart [C]

BRIDGE: root chord

X 3 X 1 X 2

And [F] love... [C] we [G] need it [C] now
 Let's [F] hope... [C] for [G] some [G]
 Cos [F] oh... [C] we're [G] bleeding [C] out

CHORUS:

I belong with [Am] you, you belong with [G] me
 You're my sweet-[C]heart [C]
 I belong with [Am] you, you belong with [G] me
 You're my sweet

OUTRO:

[C] Ho [F]↓↓[C] Hey [F]↓↓[C] Ho [F]↓↓ [C] ↓ Hey

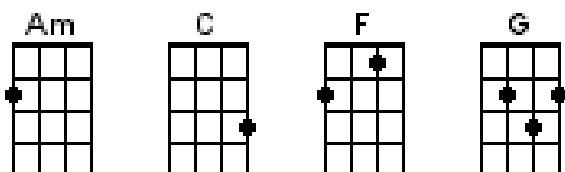

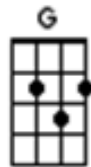
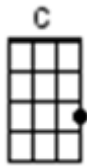
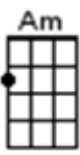
Riptide Vance Joy

Intro 1 2 / 1 2 /

[Am] / [G] / [C] / [C] /

[Am] / [G] / [C] / [C] /

VERSE 1:

[Am] I was scared of [G] dentists and the [C] dark [C]

[Am] I was scared of [G] pretty girls and [C] starting conver-[C]-sations

Oh [Am] all my [G] friends are turning [C] green [C]

You're the [Am] magician's as-[G]-sistant in their [C] dreams [C]

A-[Am]oh, [G] oh [C] oh [C]

A-[Am]oh, [G] oh.... and they [C]↓ come unstuck

CHORUS:

[Am] Lady, [G] running down to the [C] riptide

[C] Taken away to the [Am] dark side

[G] I wanna be your [C] left hand man [C]

I [Am] love you [G] when you're singing that [C] song, and

[C] I got a lump in my [Am] throat 'cause

[G] You're gonna sing the [C] words wrong [C]



VERSE 2:

[Am] There's this movie [G] that I think you'll [C] like [C]

This [Am] guy decides to [G] quit his job and [C] heads to New York [C] City

This [Am] cowboy's [G] running from him-[C]-self [C]

And [Am] she's been living [G] on the highest [C] shelf [C]

A-[Am]oh, [G] oh [C] oh [C]

A-[Am]oh, [G] oh and they [C]↓ come unstuck

Chorus:

[Am] Lady, [G] running down to the [C] riptide

[C] Taken away to the [Am] dark side
 [G] I wanna be your [C] left hand man [C]
 I [Am] love you [G] when you're singing that [C] song, and
 [C] I got a lump in my [Am] throat, 'cause
 [G] You're gonna sing the [C] words wrong [C] arpeggio fill

BRIDGE:

[Am] I just wanna, [Am] I just wanna [G] know [G]
 [C] If you're gonna, [C] if you're gonna [F] stay [F]
 [Am] I just gotta, [Am] I just gotta [G] know [G]
 [C] I can't have it, [C] I can't have it [F]↓ any other way

I [Am]↓ swear she's [G]↓ destined for the [C]↓ screen.....
 [Am]↓ Closest thing to [G]↓ Michelle Pfeiffer [C]↓ that you've ever seen, oh

CHORUS:

[Am] Lady, [G] running down to the [C] riptide
 [C] Taken away to the [Am] dark side
 [G] I wanna be your [C] left hand man [C]
 I [Am] love you [G] when you're singing that [C] song, and
 [C] I got a lump in my [Am] throat, 'cause
 [G] You're gonna sing the [C] words wrong [C]



Ah [Am] Lady, [G] running down to the [C] riptide
 [C] Taken away to the [Am] dark side
 [G] I wanna be your [C] left hand man [C]
 I [Am] love you [G] when you're singing that [C] song, and
 [C] I got a lump in my [Am] throat, 'cause
 [G] You're gonna sing the [C] words wrong
 [C] I got a lump in my [Am] throat, 'cause
 [G] You're gonna sing the [C]↓ words wrong

Under The Boardwalk (*Young & Resnick*) (1964) as recorded by The Drifters**INTRO: 1 2 1 2 3 4 [G] [G]**

Oh when the [G] sun beats down

And burns the [G] tar upon the [D7] roof [D7]

And your [D7] shoes get so hot

You wish your [D7] tired feet were fire-[G]proof [G7]

Under the [C] boardwalk, down by the [G] se-e-ea, ye-a-ah

On a [G] blanket with my ba-[D7]by, is where I'll [G] be [G↓] [G↓]

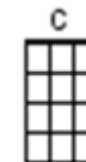
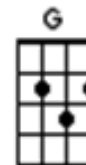
**Chorus** Under the [Em] boardwalk (*out of the sun*)Under the [D] boardwalk (*we'll be having some fun*)Under the [Em] boardwalk (*people walking above*)Under the [D] boardwalk (*we'll be falling in love*)

Under the [Em↓] board-[Em↓] walk [Em↓] board-[Em↓] walk

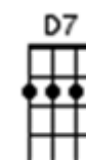

From the [G] park you hear

The happy [G] sound of a carou-[D7]sel, mm-[D7]mm

You can [D7] almost taste

The hot [D7] dogs and french fries [G] they sell [G7]

Under the [C] boardwalk, down by the [G] se-e-ea, ye-a-ah

On a [G] blanket with my ba-[D7]by, is where I'll [G] be [G↓] [G↓]

**Chorus** Under the [Em] boardwalk (*out of the sun*)Under the [D] boardwalk (*we'll be having some fun*)Under the [Em] boardwalk (*people walking above*)Under the [D] boardwalk (*we'll be falling in love*)

Under the [Em↓] board-[Em↓] walk [Em↓] board-[Em↓] walk

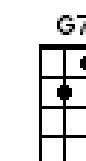
**Instrumental break**

From the [G] park you hear The happy [G] sound of a carou-[D7]-sel, mm-[D7]mm

You can [D7] almost taste The hot [D7] dogs and french fries [G] they sell [G7]

Under the [C] boardwalk, down by the [G] se-e-ea, ye-a-ah

On a [G] blanket with my ba-[D7]by, is where I'll [G] be [G↓↓] [G↓]

Chorus Under the [Em] boardwalk (*out of the sun*)Under the [D] boardwalk (*we'll be having some fun*)Under the [Em] boardwalk (*people walking above*)Under the [D] boardwalk (*we'll be falling in love*)

Under the [Em↓] board-[Em↓] walk [Em↓] board-[Em↓] walk



Back in the USSR (Lennon/McCartney) The Beatles in A major

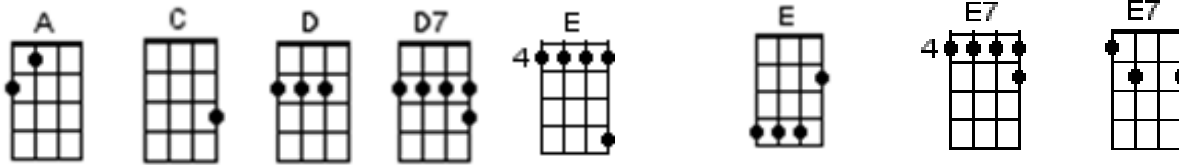

Count in 1 2 1 2 3 4

Starting note is

Intro [E][E][E][E7] Ohhh

[A] Flew in from Miami Beach B [D] O A C

[C] didn't get to bed last [D] night

[A] On the way the paper bag was [D] on my knee

[C] Man I had a dreadful [D] flight

I'm back in the U.S.S.[A]R.

[C] You don't know how lucky you [D] are boy

[D↓] Back in the U.S.S.[A] R. [A↓] [D↓][Eb↓] [E↓]

[A] Been away so long I hardly [D] knew the place

[C] Gee it's good to be back [D] home

[A] Leave it 'till tomorrow to un-[D]-pack my case

[C] Honey disconnect the [D] phone

I'm back in the U.S.S.[A] R.

[C] you don't know how lucky you [D] are boy

[D↓] Back in the U.S.

[D↓] Back in the U.S.

[D] Back in the U.S.S.[A]R. [A7]

Well the [D] Ukraine girls really [D7] knock me out, _{D/B}

They [A] leave the West behind

And [D] Moscow [D/C#] girls make me [D/C] sing and shout [D6]

That [E] Georgia's always on my mi mi

[D] mi mi mi mi mi mi [A] mind [A↓] [D↓] [Eb] [E↓]

Instrumental verse

[A] Flew in from Miami Beach B [D] O A C

[C] didn't get to bed last [D] night

[A] On the way the paper bag was [D] on my knee

[C] Man I had a dreadful [D] flight

I'm back in the U.S.S.[A]R.

[C] You don't know how lucky you [D] are boy

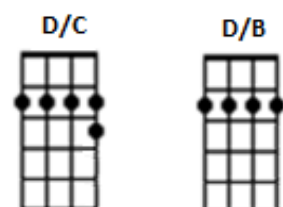
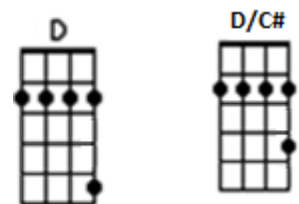
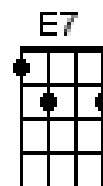
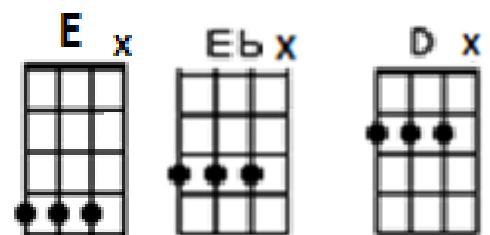

[D] Back in the U.S.S.[A]R. [A7]

Well the [D] Ukraine girls really [D] knock me out,
they [A] leave the West behind

And [D] Moscow [D/C#] girls make me [D/C] sing and shout [D6]

That [E] Georgia's always on my mi mi

[D] mi mi mi mi mi mi [A] mind [A↓] [D↓] [Eb] [E↓]

Oh [A] show me 'round your snow-peaked mountains [D] way down south

[C] Take me to your daddy's [D] farm,

[A] Let me hear your balalaikas [D] ringing out

[C] Come on keep your comrade [D] warm

I'm back in the U.S.S.[A]R.

[C] You don't know how lucky you [D] are boy

[D] Back in the U.S.S.[A] R



Are you one of the many ukulele players who avoids any song with the dreaded E chord.

Just look at the large chord window below and you will see that you need ONLY three notes to play the E chord. These are B E & Ab on the 4th fret. There is no need for duplicated the extra B note on the second fret of the 1st string.

So play the easier one where you just touch the first string with one of your fingers to deaden it stop it sounding.

I have placed an X above the first string, which means don't play that string.

Simples!

You will find as your hands and fingers become stronger and more mobile that you will be able to play the full E chord at a later date.

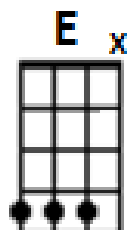
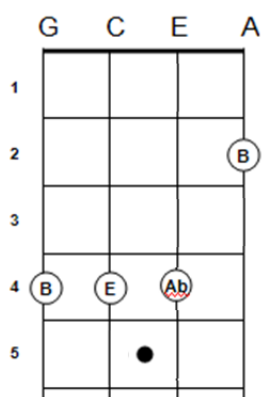

C major

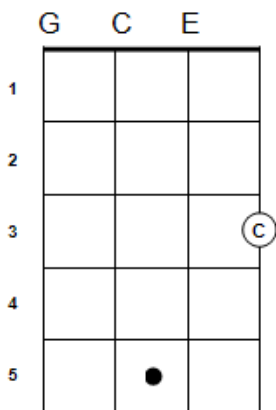

D major

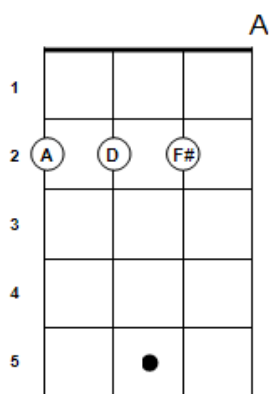

A major

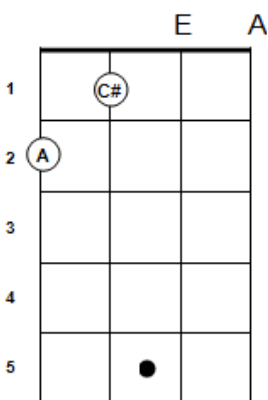

Eb major

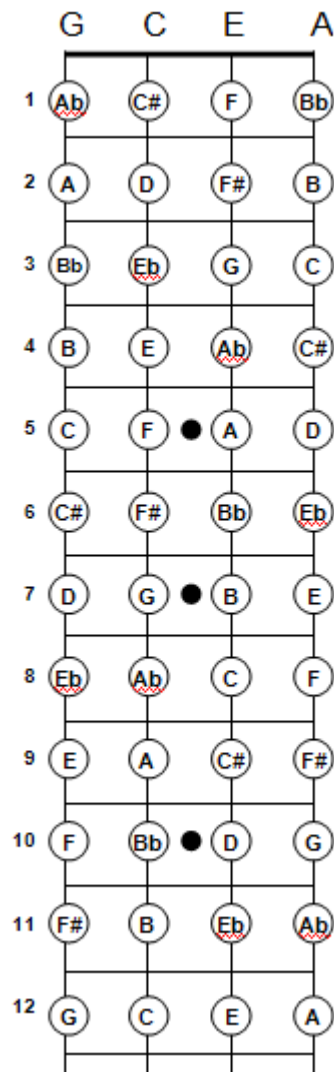
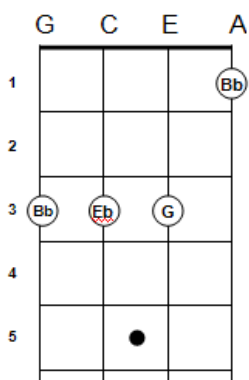

F major

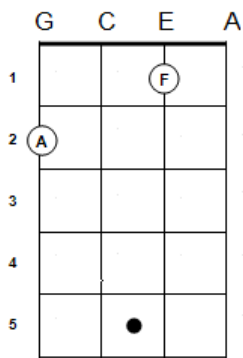

E Major

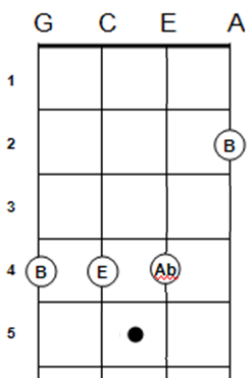

G major

